

# ELECTRICAL COMMUNICATION

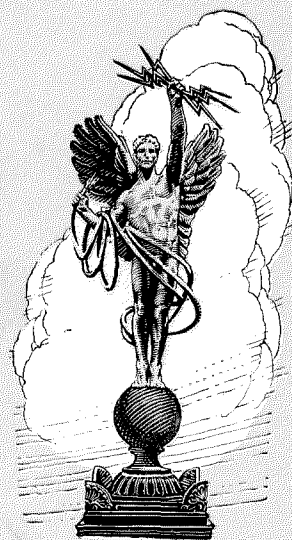

APRIL  
1927

No. 4  
VOL. 5

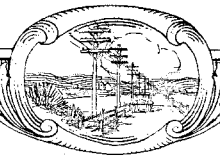

# ELECTRICAL COMMUNICATION

A Journal of Progress in the  
Telephone, Telegraph and Radio Art

## EDITORIAL BOARD

J. L. McQuarrie      F. Gill      G. Deakin      P. E. Erikson      G. H. Nash  
G. E. Pingree      P. K. Condict      W. E. Leigh      E. A. Brofos      E. C. Richardson      F. A. Hubbard  
H. T. Kohlhaas, Editor

Published Quarterly by the

***International Standard Electric Corporation***

Formerly

***International Western Electric Company***

INCORPORATED

Head Offices

41 BROAD STREET, NEW YORK, N. Y., U. S. A.

European General Offices

CONNAUGHT HOUSE, ALDWYCH, LONDON, W. C. 2, ENGLAND

75, AVENUE DES CHAMPS-ELYSEES, PARIS (8e), FRANCE

G. E. Pingree, President

L. N. Rock, Secretary

H. B. Orde, Treasurer

Subscription \$1.50 per year; single copies 50 cents

Volume V

APRIL, 1927

Number 4

## CONTENTS

PIONEERS OF ELECTRICAL COMMUNICATION — ALESSANDRO VOLTA—III. . . . .	235
<i>By Rollo Appleyard</i>	
COMPOSITE TELEGRAPHY AND TELEPHONY ON OPEN WIRE LINES. . . . .	250
<i>By A. E. Thompson</i>	
TOLL SWITCHBOARD NO. 3. . . . .	255
<i>By J. Davidson</i>	
RADIO TELEPHONY APPLIED TO ANTARCTIC WHALE HUNTING. . . . .	260
<i>By E. A. Rattue</i>	
ICELAND AND ITS FIRST BROADCASTING STATION. . . . .	267
<i>By Keith H. Thow</i>	
SOME FEATURES OF THE LONG DISTANCE TELEPHONY EXHIBITION IN PARIS. . . . .	273
A MODERN HIGH-VOLTAGE CABLE-TESTING PLANT. . . . .	284
<i>By T. N. Riley</i>	





Portrait of Volta by Giovita Garavaglia, reproduced from *Elogio Scientifico di Alessandro Volta*, which was published at Como in 1834

# Pioneers of Electrical Communication

## ALESSANDRO VOLTA—III

By ROLLO APPLEYARD

*European Engineering Department, International Standard Electric Corporation*

FROM May to October of the present year, representatives of scientific societies, engineering institutions, and electrical industries throughout the world, will meet at Como, the native city of Volta, to congratulate Italy upon having produced this philosopher, who, in the wilderness of electrical science, revealed a new realm. The moment, therefore, is appropriate for paying homage to his memory by recalling such details as may help to invest with reality what can be discerned of the man himself, and such facts as are known concerning his achievements.

Alessandro Giuseppe Antonio Anastasio Volta was born on February 18, 1745. His descent can be traced to Zanino Volta of Lovenno, and to Martino Volta who in the year 1500 was a merchant of Venice, trading in wool on the Rialto. The parents of Alessandro were Philippe Volta and Madeleine de Conti Inzaghi. With a happy disposition, great powers of application, a sense of order, and his father's guidance in his studies, he soon attained an enviable place amongst his fellows at the public school of Como. The Royal Seminary at Como put the finishing touches upon his education, and as far as can be judged, his early leanings were towards prose and verse. By the time he was 24, however, chemistry and electricity cast upon him spells that caused Italy to lose a poet, and natural science to gain a pioneer.

Volta was not destined to be merely a chemist and a physicist; he became a man of affairs who directed the thoughts of Europe to noble purposes. In 1777 he travelled to Switzerland, and met De Saussure, Voltaire, and other men of thought and distinction. Two years later he was called to occupy the chair of physics at Pavia. In 1780 he visited Bologna and Florence. In 1782 he proceeded to Germany, Holland, England and France, to confer with such intellectual giants as Lichtenberg, Van Marum, Priestley, Lavoisier and Laplace, and incident-

ally to enrich the cabinet at Pavia with instruments of research and demonstration.

Volta married on September 22, 1794, at the age of 49, Donna Teresa Perigrini Ludovico. During the next five years, he wrote some of his most valuable memoirs, and secured universal fame.

To realize the conditions under which, at this time, he was carrying out his researches, it must be remembered that all Europe was at war, and that his home at Como was at the very vortex of the tempest that raged between Austria, France and Italy. In 1799 the Austrians dominated the passes of the Alps, and they determined upon an attack on Genoa. The effort was successful, but it was made at the expense of their control of the approaches to Italy. In May, 1800, Bonaparte took advantage of the strategic situation thus created, and invaded Lombardy. With 35,000 men and 5,000 horses, he traversed the narrow pass of the great St. Bernard; he occupied Aoste, he lost and then won the battle of Marengo (June 14, 1800), he conquered Lombardy, and five years later (May 26, 1805) he was crowned at Milan. His entry into Italy in 1800 was greeted with rejoicings; for the educated classes sought liberty and expected it from the French, who were regarded as deliverers, and it was the policy of Bonaparte to come to terms in order to permit of concentration elsewhere. The extinction of the Italian republics, and the reinstatement of Victor Emanuel at Piedmont, followed the swing of the European pendulum in 1814.

Time, place, and circumstance conspired to establish friendly relationships between Volta and the First Consul. In 1801, at the invitation of Bonaparte, Volta visited Paris and gave a demonstration before a large meeting of the French Institute. Scarcely had it concluded when Bonaparte proposed that Volta should receive a gold medal. He also bestowed upon

him 2,000 crowns for his travelling expenses. Moreover, he decorated him with the Croix of the Légion d'Honneur and with the Couronne de Fer. He nominated him a member of the Italian Consulate, and he raised him to the dignity of Comte and Senator of the realm of Lombardy.

By immortalising his name in the unit of electro-motive force, electricians long ago placed their laurels upon Volta. Testimony of his originality and of the scope of his activities is to be found in what remains of his apparatus, and in the literature that has been so carefully brought together in Italy concerning his achievements. Unfortunately, a considerable amount of his original apparatus was destroyed in the disastrous fire that occurred at Como on July 8, 1899. Some of it was saved, however, and photographs exist of most of the instruments as they appeared before the calamity.

In the course of a recent visit to Italy it has been possible, through the courtesy of Professor Felice Scolari and of the Director, Mgr. Baserga, to examine these relics at the Museum in Via Giovio, Como, and to obtain the illustrations here reproduced. In addition, by the kind permission of Professor Francesco Massardi, it was possible to examine at the Reale Istituto Lombardo, in the Palazzo Brera, Milan, the original manuscripts of Volta and certain reproductions scrupulously prepared of essential portions of the apparatus as it existed prior to the fire.

Remarkable evidence of Italy's determination to do justice to the memory of Volta is to be found in "Le Opere di Alessandro Volta Edizione Nazionale." This work, in seven volumes, is approaching completion; it will contain the copious private correspondence of Volta, relating to scientific and other subjects, and will include letters to such of his contemporaries as Priestley, Sir Joseph Banks and Benjamin Franklin, together with the famous memoir of 72 pages written by Volta in the form of a letter to his friend Joannem Baptistam Beccariam, Professor at the Turin University, in 1769, entitled "De Vi attractiva ignis electrici," containing the germ of the idea of the electrophorous. The famous "Raccolta Voltiana," published at Como in 1899 as a tribute to Volta, includes an excellent series of illustrations of the

apparatus, from which many of the figures for the present article have been prepared.

The century that has elapsed has confirmed the value of the discoveries associated with the name of Volta: the electrophorous, the Volta "pistol," the "lampada a gas," the eudiometer, electric signalling, the condensing electroscope, the apparatus for exploring the electric charges in the atmosphere by means of a flame, and the Volta pile in its various forms. At this distance of time, taking into account the lack of facilities that existed towards the close of the eighteenth century for communicating and publishing ideas relating to physical science, it is necessary to exercise reserve concerning Volta's priority in relation to some of these items. In the main, however, the evidence in his favour with regard to most of them is sufficiently convincing to establish his right to be honored as the inspiring genius who by incontrovertible experiment transformed electrical science from a polite amusement into a means of conferring limitless benefits of a practical character upon mankind.

These electrical investigations of Volta mark the transition from the old régime of electrostatics to the dynasty of galvanic action. At the age of 18 he was in correspondence with the French philosopher, Jean Antoine Nollet (1700-1770), who had distinguished himself in 1746 by sending a shock from a Leyden jar through 180 of the Royal Guards. Nollet had experimented upon pointed conductors, and upon the evaporation of fluids by electricity. He had also (1748) shown the relationship between lightning and the electric spark, and it was to Nollet that Etienne du Tour had addressed his account of the effect of a flame upon electrified bodies (1745). According to Arago the first electrometer (1749) is due to Darcy and Le Roy. Nollet suggested the more sensitive form in which two wires open like the legs of a compass; Cavallo added a small sphere at the end of each of the two wires, and Volta obtained increased sensitiveness by substituting a pair of dry straws.

In 1776 or 1777 Volta introduced his hydrogen-lamp (Figure 1-1) and his electric igniter (Figure 1-2). He was probably the first to ignite inflammable gases in closed vessels. His "pistol" (Figure 2) dates from about the same



time. It led to further experiments upon the ignition of inflammable gases by electric sparks, and it entered into his scheme for electrical

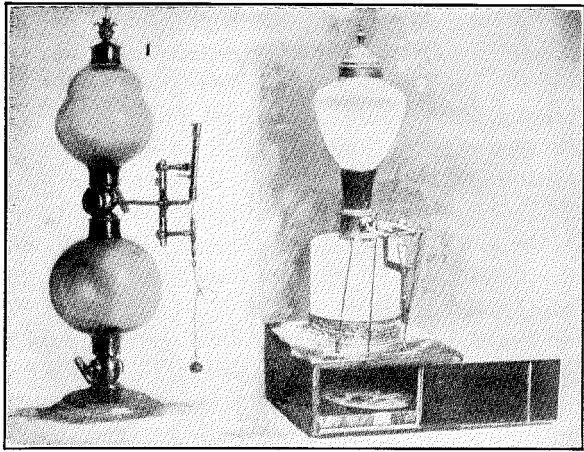

Figure 1—Volta's Hydrogen Lamp (1), and Electric Igniter (2)

communication. His proposal is indicated in Figure 3 which was prepared from a sketch sent by him to his friend Barletti, Professor of Physics at the University of Padua, to show how a signal might be transmitted electrically from Como (left) to Milan (right). An iron transmission wire A B was to be supported on insulating posts a, b, c, d. The return circuit was to be through the canals and streams shown in Figure 3 above the transmitting wire. A Leyden jar discharged into the transmission line at Como was to detonate a "pistol" at Milan.

It is right to add that the principle of such a method of electrical communication was known long before 1776. In the *Philosophical Transactions of the Royal Society* for 1745, Volume 43, William Watson gives an account of a method of firing bodies electrically and he refers to the ignition of gas by electric sparks. Moreover, in those *Transactions* for 1748, Volume 45, there is a description of experiments in which certain Fellows of the Royal Society contrived to make the shock from a Leyden jar traverse a circuit of two miles, and in one case of nearly six miles. They also succeeded in signalling in this manner across the Thames at Westminster Bridge. In the same volume there is further a reference to a paper concerning electrical experiments closely resembling these, by "an ingenious gentleman, Mr. Franklin."

The evolution of the electrophorous is somewhat difficult to trace. In England, John Canton (1718-1772) established the principle of electro-static induction. In Stockholm, Johann Karl Wilcke (1732-1796), and in Berlin, Franciscus Alpinus (1724-1802), found that a plate of air could be charged like a plate of glass. Volta applied the principle of electro-static induction, and designed the electrophorous with such knowledge and skill that no improvement upon it has been found during the century.

At about the time he had perfected the electrophorous, it may be assumed that he was perplexed by the question of the best means of disclosing to the scientific world ideas that had matured in his mind, and that he desired to ascertain what was known elsewhere concerning his subject and kindred matters. In the spring of 1782 he journeyed to England. He examined the manufacturing centres, the canals, and the harbours. He saw Oxford University and Blenheim Castle, the factories of Birmingham and Manchester, and the salt-mines of Nantwich, and he included in his tour Chester, Shrewsbury, Bridgnorth, Worcester,

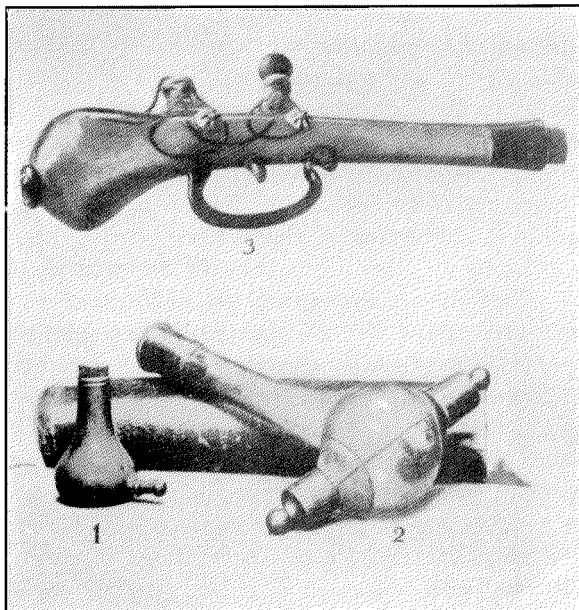

Figure 2—Volta's "Pistol"

Gloucester, Bath, Bristol and Liverpool. At Portsmouth he visited the Fleet, under Admiral Howe, of 20 ships of the line, and went on

board H.M.S. Regina of 98 guns; and at Greenwich he went over the Royal Observatory.

During this stay in England he became acquainted with Dr. Joseph Priestley (1733-1804), Sir Joseph Banks (1743-1820) and other Fellows of the Royal Society, with the result that on

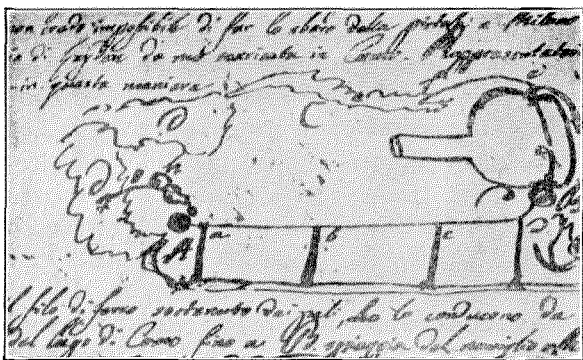

Figure 3—Volta's "Pistol" Applied for Receiving a Signal

March 14, 1782, a paper by "Mr. Volta. Professor of Experimental Philosophy in Como," was communicated to that Society by the Right Honorable George Earl Cowper, F.R.S., and was published in the Transactions of that year, Volume 72, page 237, under the title, "The Method of Rendering Very Sensible the Weakest Natural or Artificial Electricity." Volta there describes his electrophorous as "a machine well known to electricians." He states that it might better deserve the name of "electrometer" or "micro-electrometer," but that he preferred to call it a "condenser of electricity."

It appears, therefore, that he recognized it as primarily an apparatus for facilitating the measurement of electric charges, rather than as a generator of static charges. In this manner he associated it with his condensing electroscope—which could be used for detecting extremely small charges—and thus was able to show clear signs of electricity accompanying such processes as evaporation of water, the combustion of coal, and the effervescence of "iron filings in dilute vitriolic acid."

The illustrations in Figures 4, 5 and 6 are evidence of the excellence of the designs perfected by Volta in the electrophorous and the condensing electroscope. He advocated the use of a very thin (e.g., 1/50 inch) resinous coating, and he insisted upon full and flat contact be-

tween it and the metal plates. Time must be allowed "till the metal plate may have acquired a sufficient quantity of electricity." For meteorological observations, the "atmospherial conductor," which De Saussure added to Cavallo's electrometer in 1785, presumably an apparatus like Figure 7, and to which Volta added a flame, was to have "the fewest joints possible." Further observations recorded in this famous communication by Volta are to the effect that: (1) by slightly melting the surface of the resin in the sun, it loses all its charge; (2) the flame of a candle or of a piece of paper will discharge it; (3) fine hair is a sensitive detector; (4) fusion, or a strong degree of heat, renders every body a conductor of electricity; (5) the augmentation of the phenomena is greater in proportion as the body which supplies the metal plate of the condenser with electricity has "a greater capacity"; (6) the electricity "cannot be accumulated beyond a certain degree," i.e., beyond the condition when it begins to be dissipated; (7) to avoid the inconvenience in certain experiments of the resin retaining its charge, it may be useful to try partial conductors like wood or marble which do not "contract" electricity; (8) for this purpose, old marble was found to be better than new; (9) surfaces should

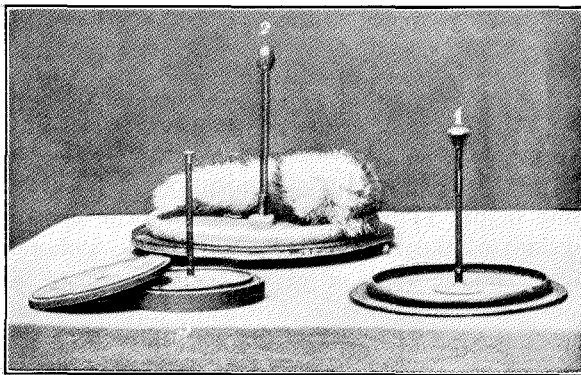

Figure 4—The Electrophorous, Said to Have Been Invented by Volta in 1775. It gave him world-wide fame. Attention was directed to its importance by Dr. Priestley

coincide so well as to exhibit cohesion; (10) copal, amber or lac varnish is recommended on marble, or on a truly flat metal plate; (11) cloth, satin, silk, paper, leather, ivory or bone, if well dried, may be used for condensers; (12) a Leyden phial which appears to be deprived

of its charge when the coatings are momentarily connected, gives further sparks if allowed time to recover; (13) "Capacity is inversely as the intensity, by which word I mean the endeavour by which the electricity of an electrified body

The state of electrical knowledge before 1782 may be gathered from the communication by the Honorable Henry Cavendish, contained in the Transactions of the Royal Society, Volume 66, 1776, page 196, read on January 18, 1775, with the title "An Account of Some Attempts to Imitate the Effects of the Torpedo by Electricity." Cavendish used 49 Leyden jars of extremely thin glass, disposed in seven rows. He compared their capacity quantitatively with that of a plate condenser of crown-glass dielectric, of known dimensions. He found the capacity of a condenser to be directly as the area of the coating and inversely as the thickness of the glass, whereby the proportion of the quantity of electricity in the jars to that in the plate-condenser was computed by charging to a definite difference of potentials as determined by his somewhat crude electrometer. He calibrated the electrometer by dividing the charge of one jar between two similar jars. He then charged a row of Leyden jars, and observed how many times it was necessary to charge the plate condenser from the row of jars in order to reduce the potential of the row to one-half the initial value. Finally he deduced the ratio of the quantity of electricity in the row to the

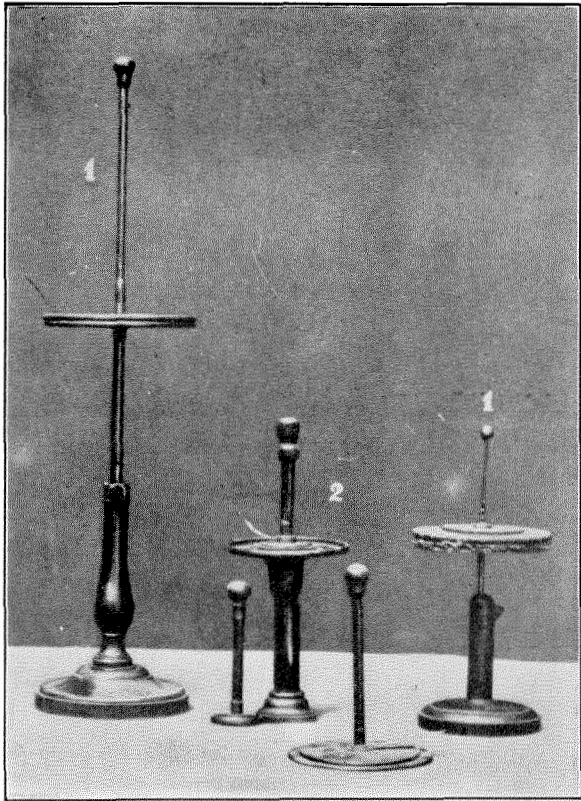

Figure 5—Volta's Condensing Electrostatic Machine (1). The condenser (2) is said to have been charged by the evaporation of liquids. These are from the Istituto Lombardo

tends to escape from all parts of it"; and (14) the capacity of two conjugate conductors increases as they are brought nearer together, the quantity meanwhile remaining constant except for leakage and the intensity diminishing.

Arago describes Volta's condensing electrostatic machine as a veritable microscope, and in the hands of the pioneers, it has been a valuable aid to quantitative research. There is satisfaction in recording that Volta was elected a foreign Fellow of the Royal Society in 1791, chiefly on account of the discoveries disclosed in his communication of 1782; an acknowledgment which encouraged him to march forward to experiments that revealed him in the domain of physical science a king in his own right.

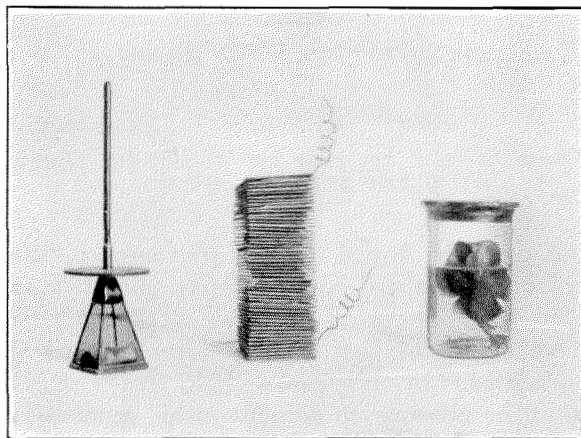

Figure 6—Volta Apparatus Preserved at the University of Pavia, Including a Condensing Electrostatic Machine (1), a Pila of Square Form, and a Torpedine Preserved in Alcohol

quantity of electricity in the plate, and by applying the logarithmic law he deduced "the quantity of electric fluid in the row." The fact that the theory of the condenser was known before Volta, however, in no way detracts from



the value of his work on the condensing electro-scope.

To close the account of this middle period of his career, it is appropriate to recall the words of his contemporary Thomas Thomson, the his-

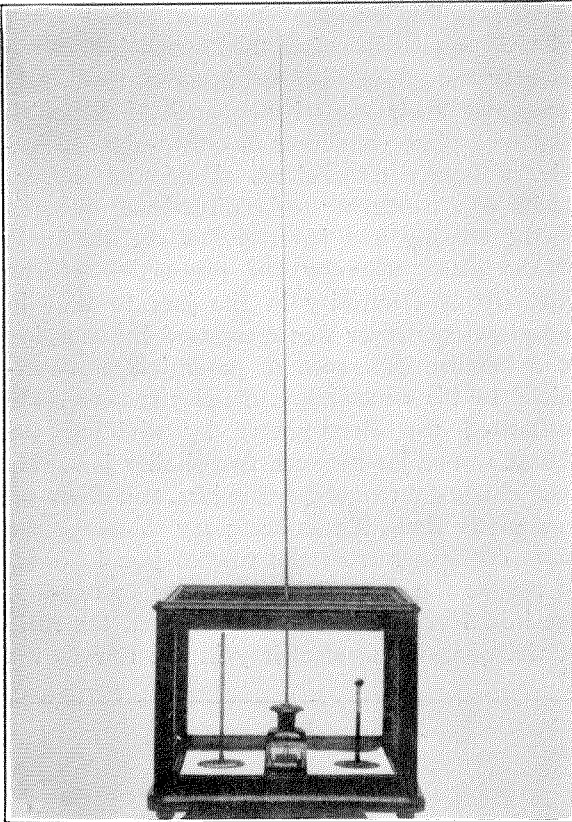

Figure 7—Volta Apparatus for Investigating Electric Charges in the Atmosphere

torian of the Royal Society who wrote: "We are more indebted to Mr. Volta than to any other philosopher of the present age for the introduction of new and important electrical apparatus. In this Paper (Phil. Trans. R.S., 1782) he gives us an account of his condenser; a very useful instrument for detecting the presence of small quantities of electricity. By means of it Lavoisier, Laplace and himself, succeeded in ascertaining the existence of negative electricity in the vapour of water, the smoke of burning coals, the air produced by the solution of weak sulphuric acid, . . ."

The years following 1782 were not spent wholly in Italy. With his friend Antonio Scarpa, Professor of Anatomy at Pavia, Volta

went to Vienna where the Emperor Joseph II received him in a most friendly manner. In 1784 he visited Berlin, and in 1787 he was at Geneva discussing French poetry with De Saussure. Then happened the insignificant event that, like a microscopical crystal falling into a super-saturated solution, converted the limpid facts and opinions of his mind into a brilliant notion. On August 30, 1789, Luigi Galvani of Bologna observed by chance the convulsions of a dead frog that was in contact with metal.

Galvani's memoir entitled "De viribus electricitatis in motu musculari commentarius" appeared in 1791, at a time when Volta was engaged upon his investigations upon inflammable marsh gas. On April 3, 1792, he wrote to Galvani concerning the frog movements, and a few weeks later he spoke in praise of the discovery. During the summer of 1792, however, he became dissatisfied with Galvani's explanation of the phenomena, and he concentrated upon the problem of contact-electricity. His investigations at this stage, in so far as they relate to the story of Galvani, will receive treatment in another installment of this history of the pioneers. To clear the issue, however, it may be observed that the Royal Society awarded the Copley Medal to Volta in 1794, six years before his invention of the pile, and that on the occasion of the award Sir Joseph Banks, the President, said:

"The experiments of Professor Galvani, until commented upon by Professor Volta, had too much astonished, and perhaps, in some degree perplexed many of the learned in various parts of Europe. To Professor Volta was reserved the merit of bringing his countryman's experiments to the test of sound reasoning and accurate investigation; he has explained them to Dr. Galvani himself and to the whole of Europe, with infinite acuteness of judgment and solidity of argument; and through the medium of the 'Philosophical Transactions' he has taught us, that the various phenomena which presented themselves under the modifications of Dr. Galvani's experiments hitherto tried, are wholly owing to the excessive irritability of the nerves when subjected to the actions of portions of the electric fluid, too minute to be discovered, even by the delicate elec-

trometer of our ingenious brother, Mr. Bennet of Worksworth; and he has detected in the metals, which Dr. Galvani considered as mere agents in conducting his animal electricity, that very existing principle which the Doctor and his followers had overlooked."

Volta's work here deserves to be considered separately from that of the subsequent period, for he had not yet discovered the Volta pile. It is necessary first to introduce Tiberius Cavallo, an Italian physicist resident in England, who in 1775 published in London a treatise on atmospheric electricity. His observations were made at Islington. His book which went into several editions, described a multiplier, a condenser, methods of producing electric alarms, and other matters. He was responsible for improvements in the electrometer and was elected to the Royal Society. To Cavallo, Volta wrote, in French, giving an account of "Some Discoveries Made by Mr. Galvani of Bologna, with Experiments and Observations on Them." The first part of Volta's letter is dated September 13, 1792. The second part, which is a direct continuation of the first, is dated October 25, 1792. This letter was communicated to the Royal Society, and it was published in the Transactions of 1793, Volume 83, page 10.

In a generous and prophetic phrase, Volta sums up in this letter his opinion of Galvani's memoir:

"Il contient une des plus belles et des plus surprenantes découvertes, et le germe de plusieurs autres."

He explains Galvani's views, and he expresses the opinion that the electricity does not act immediately upon the muscles, but upon the nerves that excite the muscles. Again it was the instrumental value of the discovery that appealed to him—for here was an électromètre animal. He tried the effect of a two-metal probe upon detached portions of animals, and upon fragments, without any special preparation of the nerves. Then he proved that there was no need to suppose there was a discharge of electricity between nerve and muscle. With two probes of the same metal—alike in hardness, rigidity, polish, and general surface, ap-

plied in the same manner—there was no convulsion.

His field of inquiry possessed no boundaries. He acquired intuitively the secret of successful experiment—the orderly extension, with a definite object, of all investigations to cases beyond the limits that convention may consider to be reasonable. Thus in these tests, though he failed with earth-worms, snails and oysters to cause convulsions, he risked the opprobrium of anti-vivisectionists of future centuries, by extending his trials to other forms of life. Then he succeeded, and he was thus able to associate the action with the nerves of flexor muscles. His usual method in these tests consisted in decapitation, the insertion of a tinfoil strip into the neck, and the placing of a contact-plate of silver upon the body. He wickedly confesses to Cavallo:

"Il est fort amusant d'exciter de cette manière le chant d'une cigale."

He found that, whereas a specimen cut half an hour or even an hour after death, from a leg of a lamb and, therefore, almost cold and incapable of responding to any mechanical or chemical stimulus was powerfully affected by an electric stimulus, a specimen from the heart removed from the same animal soon after death, still warm and, therefore, "très irritable," treated in the same way by the "arc-conducteur," exhibited no effect. He concluded that electricity does not stimulate the involuntary heart muscles but only those subject to the will.

In this communication (1793), Volta is careful to state that Galvani was the first to show that the electric stimulus of the nerves results in excitation of the muscles, although the electric current itself may not reach the muscles. He also describes an experiment in which he placed the bowl of a silverspoon on one side of his tongue and tinfoil on the other. He expected a movement, but he experienced instead a taste. Upon reflection he was reminded that the nerves of the tongue relate to taste and not to movement. The motor nerves are further back. Accordingly he tried the root of a lamb's tongue—the effect was to raise the point of it, and to cause it to turn one way or the other. The basic conclusion at which he arrived as the

result of this series of researches (1793) cannot be expressed better than in his own words:

"C'est véritablement une nouvelle loi bien singulière, que j'ai découverte; une loi qui n'appartient pas proprement à l'électricité animale, mais à l'électricité commune, puisque ce transfux de fluide électrique, transfux qui n'est pas au surplus momentanée, comme serait une décharge, mais continu et suivi tout le temps que la communication entre les deux armures subsiste, a lieu, soit que celles-ci se trouvent appliquées aux substances animales vivantes ou mortes, ou à d'autres conducteurs non métalliques, mais suffisamment bons comme à l'eau, ou à des corps mouillés."

The earlier history of the effects of electricity upon animals probably extends to remote observations. Of recorded experiments, the most important is that contained in Sulzer's "Theorie der angenehmen und unangenehmen Empfindungen." The copy in the British Museum Library is translated from the French and is dated Berlin, 1762. This account (page 62) is literally as follows:

"Wenn man zwey Stücken Metall, ein bleyerne und ein silberne, so mit einander vereinigt, dasz ihre Ränder eine Fläche ausmachen, und man bringt sie an die Zunge, so wird man einen gewissen Geschmack daran merken, der dem Geschmack des Eisenvitriols ziemlich nahe kömmt, da doch jedes Stück besonders nicht die geringste Spur von diesem Geschmacke hat. Nun ist es nicht wahrscheinlich, dasz bey dieser Vereinigung der beiden Metalle, von dem einen oder dem andern eine Auflösung vorgehe, und die aufgelöseten Theilchen in die Zunge eindringen. Man musz also schlieszen, dasz die vereinigung dieser Metalle in einen von beyden oder in allen beyden eine zitternde Bewegung in ihren Theilchen verursache, und dasz diese zitternde Bewegung, welche nothwendig die Nerven der Zunge rege machen musz, ober wähten Geschmack hervor bringe."

After the publication of Volta's work of 1792-1793, honours were bestowed upon him from all

parts of Europe, but he was not entirely free from discordant incidents. The "Raccolta Voltiana" reminds us that in October, 1796, at Pavia he was "publicamente insultato" because he was believed to be one of the principal supporters of a proposal to transfer the University of that city to Milan. From this accusation he defended himself in a written statement denying that he had favoured the transfer. Earlier in that year the municipality of Como had sent him in company with the Conte G. B. Giovinetti to compliment Bonaparte upon his entry into Milan, and he was admitted to the ducal palace and presented to the great Generale Supremo. At the end of the year he applied, unsuccessfully, to be allowed to retire from the University of Pavia.

In February, 1797, Volta, Zola, Nani and Presciani, dons of the University of Pavia, had the fortitude to protest against the Calendar proposed by the Minister of the Cisalpine Republic, which was the name given by the French to the conquered territory in Lombardy. This so much annoyed the Rector Rasori that he accused them, before the General Administration of Lombardy, of being Austrophiles—but without effect. In June, 1799, Bonaparte himself settled the question of Volta's position in the University of Pavia.

It is usual to associate Volta's conception of a continuous current with his discovery, probably towards the end of the year 1799, of the electric pile. The quotation from his letter to Cavallo, however, leaves no doubt that he had a vision of such a current in 1792, and that the production of a continuous flow became his objective. In making known to the scientific world the successful issue of these later investigations, he resorted to England as a medium of communication.

Volta's paper "On the Electricity Excited by the Mere Contact of Conducting Substances of Different Kinds" is published in the Philosophical Transactions of the Royal Society, Volume 90, 1800, pages 403-431. It is written in French, and it takes the form of a letter addressed to the Right Honorable Sir Joseph Banks, Bart., K. B., President of the Royal Society. It was read on June 26, 1800. In the History of the Royal Society it is explained that owing to the state of hostilities that then existed between

England and France, one portion of the paper arrived in London several months before an opportunity occurred for sending the remainder. This delayed publication of the discovery of the pile, and in consequence apparatus was constructed and various curious experiments by different persons in London were made in advance of the original paper being laid before the public.

Briefly, Volta explained that he had been experimenting on the electricity excited by the simple mutual contact of metals of different kinds, and other different conductors, including liquids. The result was the construction of an apparatus—the pile—which in its effects resembled those from Leyden jars, but capable of giving a continuous discharge. Then he described the construction: a number of good conductors, 30, 40 or 60 pieces, preferably of copper or better of silver, applied each to a piece of tin, or better of zinc, and an equal number of layers of water, or of some liquid which is a better conductor than water—such as salt water—or pieces of card or leather soaked with liquid and interposed between the metal discs, always in the same order. He pointed out that the apparatus resembles the organe électrique naturel of the torpedo rather than the Leyden jar, and consequently he called it the organe électrique artificiel. Some of these are illustrated in Figures 6, 8 and 9.

He took the shock or “commotion” through damp fingers, and he observed the need for good contact, as the force was very small. The effects were greater when the air was warm, as

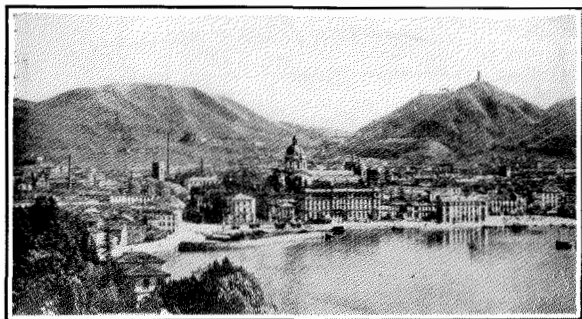

Como, Where Volta Was Born and Worked and Died. The house that was his home is at the corner of Via Alessandro Volta and Via Dell'Annunciata. It bears upon a plaque the words: "Fu Questa L'Avita case de Alessandro Volta." (Formerly the dwelling house of Alessandro Volta.)

“heat renders water more conducting”; salt added to the water gave the best conducting effect, and the effect increased with the number of “pairs.” With a view to reducing the size of the generating apparatus he designed the “couronne de tasses” (Figure 10)—30, 40 or 60 goblets half-full of pure water, or better of salt water, containing metal arcs, copper-silvered and zinc. With these he tried various arrangements of connection, rows and columns, and he investigated the effect of reversals of polarity. Such an apparatus he called an “appareil électromoteur.” He describes his sensation of commotion on contact—first “un coup et une piqure,” then “une douleur aiguë.” He also analyses the sensation at the moment of interruption, due to “a kind of reflex action of the electric fluid.” In this account he introduces the word “resistance”; he denies the existence of the *électricité animale*, of Galvani, and he affirms that of *électricité extrinsèque*, brought about by the mutual contact of metals of different kinds.

Like Cavendish before him and Maxwell after him, he was attracted to the problem of sensations caused by electrical action. He mentions that a plate of silver in contact with a plate of zinc produces an acid taste if placed upon the tongue, provided that the end of the tongue is towards the zinc, and a bitter taste (alkaline) if the metal plates are reversed—more so if an assemblage of plates is used, appropriately arranged. He found that when the current was applied to the eyes, the sensation of light was greater when a single couple was used than when 10, 20 or 30 were employed—with one electrode touching the eyeball and the other held in the hand. The most curious of these experiments, he says, is to place one metallic plate between the lips and in contact with the end of the tongue, and to complete the circuit in any convenient manner. Then, if the apparatus is sufficiently large and in good order, a sensation of light will be experienced in the eyes, the lips will be convulsed, and the end of the tongue will feel a painful pricking sensation followed by the sensation of taste.

The adaptation of his own body as a testing equipment, however, did not end there. He described experiments in which the sensation of hearing (noise) is excited by sending a current through the ears from 30 or 40 couples. He de-

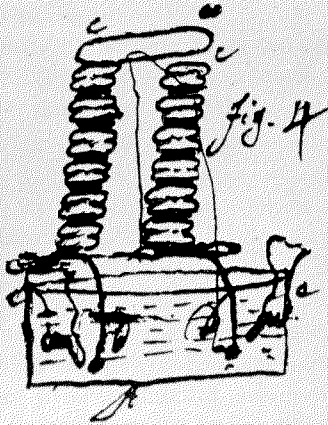

Li qui pour la réussite de ces expériences, doit être effroyable, en concevant un nombre assez grand de plateaux 60. ou même 80, 100. ou davantage.

FAC-SIMILE DI MANOSCRITTO VOLTIANO, TRATTO DALLA CELEBRE LETTERA A SIR BANKS, COLLA QUALE IL VOLTA ANNUNCIAVA L'INVENZIONE DELLA PILA. (Pubblicato nel 1° volume dell'Edizione nazionale delle opere).

je dispose les choses en man-  
 rière que les deux extrémités  
 de cet appareil viennent abou-  
 tir dans le lieu d'un seul ef-  
 fect, comme on le voit en fig. 4.  
 Dans A. représente une jarre  
 remplie d'eau, b. b' son fond  
 en lignes, provenant de deux  
 extrémités de l'appareil électrique  
 à piles. d. les mains approchées  
 à ces conducteurs; e. e' sont  
 les fils qui établissent la communication  
 avec une machine ou le carton  
 mouillé, destinée à établir la  
 communication entre les deux pi-  
 les pour compléter le circuit.  
 Si l'on veut que les deux  
 mains ne soient pas mouillées  
 on peut les approcher des  
 deux conducteurs, en s'aidant  
 de la barre c. c' appliquée à la barre  
 et au contact des deux piles, les  
 mains approchées se serviront  
 qui sera à la vérité beaucoup plus  
 faible, que si les conducteurs  
 aboutissent chacun à un vase  
 d'eau séparé comme dans les  
 cases ordinaires. Mais ce n'est  
 que pour les expériences de physique  
 que l'on a besoin de ces deux  
 piles, car pour les expériences  
 de chimie, on se sert d'une seule  
 pile, et l'on se contente de  
 rapprocher les deux extrémités  
 de la pile, ou de la faire

et la queue de l'organe  
 semblable, laquelle répondra  
 les deux extrémités de l'oreille or-  
 gane; et que, la plaque c. c'  
 au lieu de l'eau, et qu'on se  
 verra interrompre par une  
 dans ces organes, quel qu'il soit  
 où se fait une réaction  
 magnétique, l'organe d'ou  
 la se confie, etc. dans c. c' on

comme pour les expériences de  
 physique, on se sert d'une seule  
 pile, et l'on se contente de  
 rapprocher les deux extrémités  
 de la pile, ou de la faire  
 communiquer à cette pile, d'un  
 côté, avec une machine ou le  
 carton mouillé, et de l'autre  
 côté, avec les deux extrémités  
 de la pile, ou de la faire

Figure 8—Part of the Manuscript Addressed by Volta to Sir Joseph Banks, March 20, 1800, Describing the Pila and Showing Volta's Figure 4



scribes the noise as "comme si quelque pâte ou matière tenace bouillonnait." He admits that the investigation was too painful and too dangerous to be repeated. Lastly, he experimented with his nose, with the result that more pain was produced, but no sense of odour.

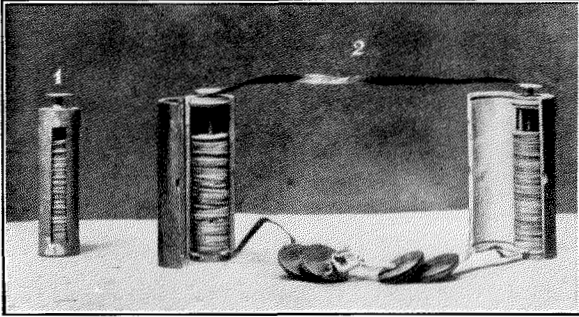

Figure 9—Prepared Frog and Apparatus Precisely As Shown by Volta to Napoleon at The Institute of France in November, 1801

Arago, his contemporary, expressed the opinion that Volta's pile was the most marvellous instrument that human intelligence had ever created and he might have added—the most mysterious. The discussion, which began in his day, regarding the seat of the electromotive-force, extends into the present century, and it is as far as ever from settlement. With a graceful tribute to Galvani, Volta referred to the effects as Galvanic phenomena. In his reply to criticism he remarked that he had never attributed to the metals exclusively the power of causing the electric effect by their mutual contact. He had proved by many experiments that this power belongs to all conductors, that it is in general more marked between metals, but that it also manifests itself in the case of metals and moist non-metallic conductors. In his view, it was necessary to form the circuit of at least three conductors—say two of the first (metallic), and the third of the second (non-metallic) class; or two of the second and one of the first, or all three of the second but all different, as in the case of the torpedo.

He confessed that in his earlier experiments upon contact, he had used a prepared frog (Figure 11) for the purpose inasmuch as he had not perfected the means of measurement. He realized that chemical as well as electrical action occurred, because in some cases gas was evolved, the metals became oxidized, and acid

was produced. Similar effects had been obtained with static electricity. By arguments such as these, free from rancour, based upon direct evidence and couched in moderate language, he held his own and convinced Europe. The mystery of cause and location remained, but as to effects he left nothing in doubt.

It was natural that in the early experiments on contact electromotive-force Volta's condensing electroscope should be requisitioned for demonstration purposes. John Cuthbertson, writing in 1805, describes an apparatus of this kind in which the copper plate is perforated with small holes, and is slightly dished. Zinc filings are then sifted through the holes and are allowed to fall upon "the top of the condensing electrometer." While sifting, the gold-leaves diverge without help from the condensing plates, and are found to be positively electrified.

At the end of the eighteenth century and at the beginning of the nineteenth, the Volta pile in innumerable forms became the vogue, and experiments on nerve and muscle a fashionable amusement. Thus, for example, John Cuthbertson, writing in 1807, describes a demonstration in which the apparatus was arranged to produce

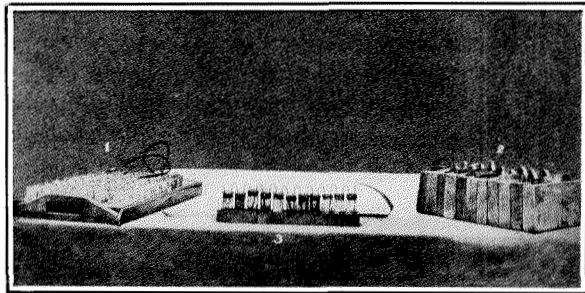

Figure 10—Volta's Pila a Corona di Tazze (1). Volta's Pila a Truogoli (trough) (2). There is also shown the Pila Secondaria of Ritter. All from the Istituto Lombardo

contractions in the head of an ox, after separation from the body.

"The eyes will open; the ears shake; the nostrils swell, and the tongue, which before hung out of the mouth, will be drawn in with violence."

Similarly for a dog, he explains that:

"Frightful convulsions may be produced. The mouth will open, the teeth will gnash,

the eyes roll in their orbits, appearing as if the animal was restored to life, and in a state of agony."

Sensationalism led to decadence, and yet he proclaims with pride:

"These experiments I had the honour of performing in the presence of their Royal

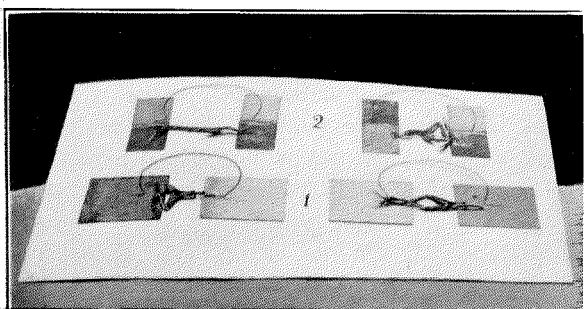

Figure 11—Volta's Frog Preparations. These investigations were in the years 1792-1800

Highnesses the Prince of Wales, the Duke of York, the Duke of Clarence and the Duke of Cumberland."

This evidence supports Whewell, who in his *History of the Inductive Sciences* states that during the twenty years that followed Volta's discovery of the pile, the impulse given by that invention to the study of electricity as a mechanical science nearly died away. In the laboratories of Europe, nevertheless, the investigation by direct experiment of contact theory had almost continuously engaged attention. Van Marum and Pfaff, of Kiel, led the way, and were joined by many others, among whom were Davy, Faraday, Kohlrausch, Pellat, Kelvin, Ayrton, Perry, and Erskine-Murray.

In this tribute to the great Italian philosopher, it must be recorded that although the mystery of contact-electricity, with which he endowed us, remains unsolved, it is still, a potent incentive to research. Maxwell, Heaviside and Kelvin were not all in complete accord concerning the action. The questions they were concerned with were: is there a metallic-junction force? When the two metals are in contact, is the air outside the zinc at a different potential from that of the air outside the copper? Is the seat of the electromotive-force at the air-surface, and if so what part is played

by the junction, remembering that a force cannot exist where it is not? Is electromotive-force a force in the Newtonian sense? Since there is no free electricity in the interior of a conductor, are the observed results to be attributed rather to free electricity associated with the conducting matter in the heterogeneous dielectric enclosing the metallic junction? What is the part, if any, played by moisture?

Volta's procedure with such perplexities was to appeal to experiment. It is appropriate, therefore, to conclude this account of his work by directing attention to the chief results of his contact-electricity investigations in the epitomized form (Figure 12) derived mainly from Lord Kelvin's contribution to the subject of contact force.

#### **Apparatus, Figure 12, i**

- (1) Place D on C. Lift them together into contact with N. Break contact with N. Lift A. No divergence of G.
- (2) Repeat (1), but instead of touching N with D, hold D two or three centimetres below N, with C still in contact with D. Lift A. Slight divergence of G.
- (3) Perform a cycle, say 100 times, as follows: (a) Break contact between C and D. (b) Make and break contact between D and N. (c) Make contact between C and D. In other words, lift D up and down between N and C. Then lift A. Great divergence of G.
- (4) Repeat (3), but maintain A at a distance from B. Bring a stick of rubbed sealing-wax near B. Divergence of G increases. Remove the sealing-wax. Divergence of G diminishes. Hence G has resinous (negative) electricity; i.e., B has received negative electricity from the copper disc D. Interchange D and C and replace sealing-wax by glass. The charge on G is then vitreous (positive).

#### **Apparatus, Figure 12, ii**

- (5) Varnish the polished opposed faces of D and C with shellac, and add contact-wires as in the Figure. Repeat (3) except that when D rests on C contact is

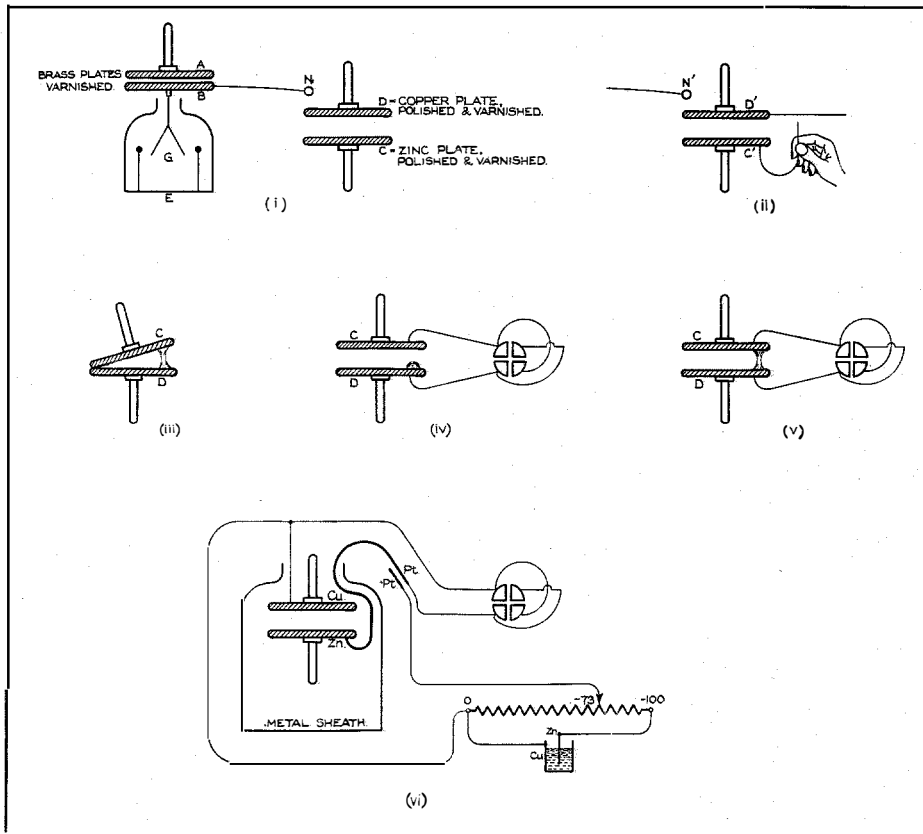

Figure 12—Volta Contact-Force Illustrations

to be made and broken by hand. If care is taken to keep the plates parallel, the electrification will now be greater than in the previous cases (1)—(4).

- (6) In (1)—(4) examine the effect of tilting the plate D while in contact with C, at the moment of separation—the electrification can thereby be greatly reduced.
- (7) Observe that experiments (1)—(4) are liable to fail if a drop of water (Figure 12, iii) is placed on C, the lower of the two polished plates. It fails if the last connection between the zinc and the copper when D is lifted, is through water.
- (8) In (7) if D is slightly tilted on lifting, so as to break the water arc before the separation between the metals—thus securing final contact between dry metals

—the experiment does not fail, nor is it substantially altered from what is found with the dry polished metals.

#### *Apparatus, Figure 12, iv*

- (9) Repeat (8) with an electrometer. (a) Let C rest on D, both being polished and dry, and note the “zero” deflection; i.e., the “metallic zero.” (b) Lift C two or three millimetres above D. There is a deflection showing that vitreous (positive) electricity has passed to the insulated quadrant of the electrometer. (c) Bring C and D again in contact. Regain “metallic zero.”
- (10) (a) Raise the zinc disc as in (9) and place a small mound of water on D. (b) Bring down C to touch the top of the mound while parallel to D so as to avoid

metallic contact (Figure 12, v). Note the deflection showing resinous (negative) electricity. (Lord Kelvin considered this motion and settlement to be "the simplest modern exhibition of Volta's greatest discovery.")

- (11) When the electrometer needle has settled, lift C about a millimetre above D until the water-column has broken, and then two or three centimetres further. The electrometer deflection does not alter. Lower C, there is still no motion of the electrometer needle—not even when C again touches the little mound of water.
- (12) Tilt C slightly (Figure 12, iii) until it makes dry metallic contact with the copper, while the water remains unbroken. At the instant of metallic contact the electrometer needle suddenly leaves its deflected position and returns to the "metallic zero."
- (13) Break the metallic contact between C and D. Hold C parallel to D with the water unbroken. The electrometer needle does not suddenly jump—it creeps slowly so that in a minute or so it reaches its previous steady state. (Lord Kelvin remarks that this effect was not known to Volta—it is the recovery of the Voltaic cell from electrolytic polarization.)

The apparatus, illustrated in Figure 12, vi, used by Lord Kelvin for obtaining quantitative measurements of the Volta electromotive-force is self-explanatory. Following Volta, special attention was given by him to the nature of the surfaces of the plates; i.e., whether dry, polished, oxidized, clean, scratched or burnished. Kelvin concluded that the Volta force is a resultant of chemical affinity between thin surface-layers of the two metals. Maxwell's view was that the greater part of the force must be sought for, not at the junction of the two metals, but at one or both of the surfaces which separate the metals from the air or other medium constituting the third element of the circuit. Heaviside suggested that on making contact between zinc and copper the first action is to remove the air from the zinc over a patch.

There the disturbance begins, i.e., at the beginning of a zinc-copper-air line round which electric current flows. The boundary of the patch thus forms the first line of magnetic force. The work done by the zinc-air force is then equated to the sum of the electrostatic energy in the condenser formed by the system, the Joule heat in the conducting system, and the work resulting from the obscure action, if any, at the copper-air surface.

In April, 1805, Volta wrote to Humboldt stating that he was engaged upon electrometry, particularly with regard to the capacity of conductors of various forms and sizes, and the relationship of capacity to electric pressure, or tension. He found that the tension diminished exactly as the capacity was augmented. The end of the most active part of his life was approaching. In July, 1808, he was asked by the representative of a Russian University to trans-

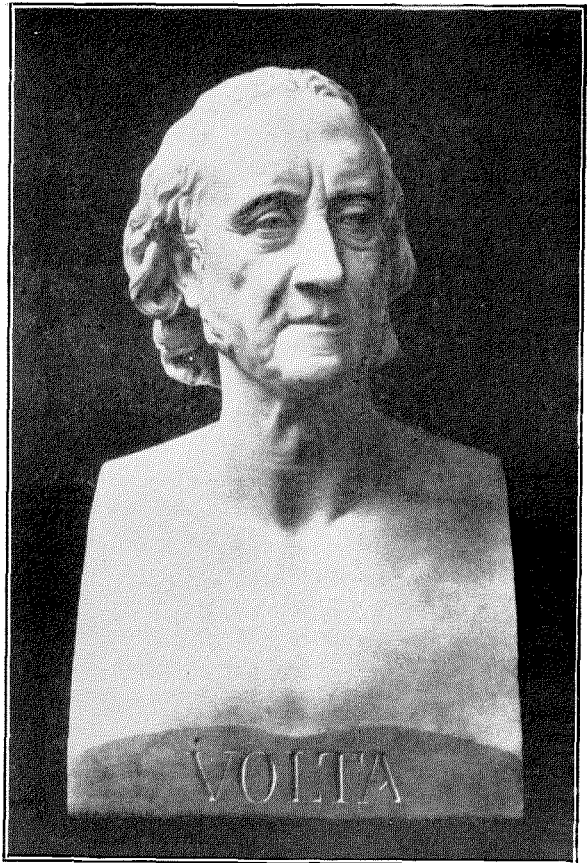

Bust of Volta. The original marble, by Gio Battista Comolli, was entirely destroyed. The illustration is from a plaster copy at the Reale Istituto Lombardo di Scienze e Lettere, at Milan.

fer his home to that country. His reply gives an indication of what his home meant to him and his outlook upon life at that time:

“Other interests more dear to my heart, and other circumstances oblige me to refuse. At the age of nearly 60, with two brothers ecclesiastics more aged who live with me, a wife, and three young children, I am too much attached to this family, who cherish me, and to a country that has not been ungracious. Happy in a moderate fortune and in an annual pension of 5,000 francs which the Government accord me as an emeritus Professor of the University of Pavia, and as a member of the National Institute, what can I desire more for the few years that remain to me? To live in peace and in repose in my country and in the bosom of my family, to occupy myself with the education of my children without

quitting my own beloved studies and my experimental researches, that is all my happiness at present, and it is for that reason that I have requested and have obtained release from the Chair of Pavia which I have held for 30 years. . . . Voila, mon respectable Professeur, ce que je dois répondre à vous, et à votre ami.”

Volta's biographers describe him as tall, large-browed and noble of mien, of regular features; and, according to Arago, of country manners contracted in his youth. So far as his manners are concerned, Arago was probably wrong, for the evidence discloses a philosopher singularly gracious, fair-minded, and companionable. In 1819 Volta quitted the University and retired to Como. His relations with the world of science then ceased. In 1823 he had a slight attack of apoplexy, and on March 5, 1827, after a fever, at the age of 82, he died.

---



# Composite Telegraphy and Telephony on Open Wire Lines

By A. E. THOMPSON

*European Engineering Department, International Standard Electric Corporation*

## Introduction

THE problem of securing additional traffic facilities from existing communication circuits is one which offers much scope for economic considerations. It attracted the attention of investigators very soon after the telegraph had proved to be of commercial importance, and various schemes for multiplying the number of message channels available without recourse to the erection of new lines had been proposed prior to the advent of the telephone.

When the telephone was born, some fifty years after the telegraph, it was perhaps inevitable that efforts to economize in line plant should have been directed towards the simultaneous operation of both services over the existing telegraph lines, and it is interesting to note how the practicability of "superimposing" was first made evident.

In both the telegraph and telephone, earthed circuits were employed with the result that inductive interference due to the sudden rise and fall of the comparatively heavy telegraph currents seriously restricted the distance over which the telephone could provide a commercial service. Van Rysselberghe, a Belgian, investigated the trouble at its source and in 1882 he was able to demonstrate that, by introducing electro-magnetic inertia in the telegraph circuits, the wave shape of the signals could be so modified that little interference would be caused in the adjacent telephone circuits.

From this principle his well known method of superimposing was evolved, the first successful trials having been made in 1885 over the telegraph lines of the Boston-Ohio Telegraph Company. Its vogue was not of long duration, however, as a telephone service derived from an earthed telegraph circuit is commercial only over comparatively short distances.

The most important range of frequencies in speech is of the order of 100 to 2,500 cycles per second. The fundamental frequency of telegraph transmission at a speed of 40 words per minute Morse is approximately 16 cycles per second,

and it is because of this considerable difference between telephone and telegraph currents that their separation is practicable.

## Composite Set

The composite telegraph and telephone system, instead of making the telephone a by-product of the telegraph, has reversed matters and generally is arranged to provide one earthed telegraph circuit over each of the two conductors

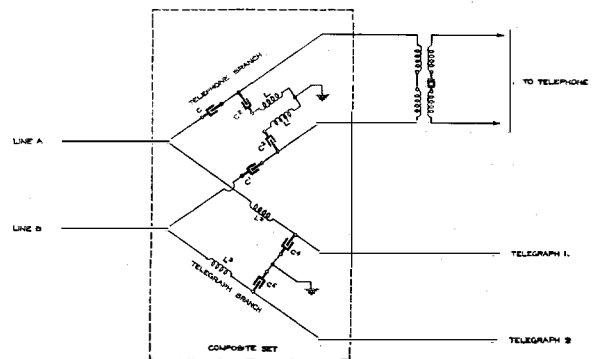

Figure 1—Schematic of Composite Set

of a telephone circuit. The equipment employed to separate the telephone and telegraph currents is called a composite set and consists of a network of inductances and capacitances which divide the circuit into two branches, one for high-frequency (telephone) and the other for low-frequency currents (telegraph), as shown in Figure 1.

In the telephone branch the condensers  $C$  and  $C_1$  act as a high impedance to the low-frequency telegraph currents and any enfeebled currents which do pass these condensers are by-passed to earth through the inductance coils  $L$ ,  $L_1$  and their associated condensers  $C_2$ ,  $C_3$ . Voice currents and 135-cycle ringing currents, for telephony, pass readily through the condensers  $C$ ,  $C_1$ . These two condensers are specially selected in order to avoid introducing any unbalance in the telephone circuit.

In the telegraph branch the inductance coils  $L_2$ ,  $L_3$  and shunt condensers  $C_4$ ,  $C_5$  offer high impedance and attenuation to speech currents

but permit telegraph currents between zero and about 80 cycles per second to pass freely to the line.

The two windings of the retardation coils, in both the telegraph and telephone branches, have negligible mutual inductance and they are enclosed in a crosstalk-proof shell. The repeating coil is used for deriving a phantom telephone circuit in the usual manner.

### Telegraph Transmission

The suppression of the higher-frequency components, or harmonics, of the telegraph waves protects the telephone service from any objectionable "Morse Thump," but it also imposes a limitation upon the speed of telegraph signaling.

The greater the number of harmonics transmitted, the more nearly do the telegraph signals approach "square wave" formation. This is illustrated in Figure 2, where curve A is composed of the fundamental plus its 3rd harmonic, and curve C the fundamental plus its 3rd, 5th, 7th and 9th harmonics.

At a speed of 16 cycles per second the telegraph dot signals transmitted over a composited circuit are composed of a sine wave plus its

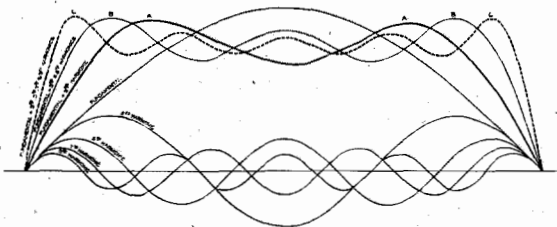

Figure 2—Fundamental Sine Wave and Harmonics

3rd and 5th harmonics. As the speed of transmission is increased, so the signals become more rounded, and at 25 cycles, which is about the maximum trustworthy speed obtainable over composited circuits, the wave-shape becomes a sine wave plus its 3rd harmonic only. (See Curve A).

The following table shows the approximate number of six-letter words per minute which can be transmitted by various telegraph systems operating at a speed of 25 cycles per second.

System	Words per Minute
Wheatstone (Morse)	60
Start-Stop	60
Baudot Multiplex (Tape Printing)	88
Western Electric and Morkrum-Klein-schmidt Multiplex (Page Printing)	90

### Types of Telegraph Systems

Either the "closed circuit" or the "double current" telegraph system may be operated on composited circuits, but "open circuit" working is not recommended as, with this system, a condenser discharge takes place at both ends of the line when the telegraph key is raised.

For duplex operation, it is necessary to place a special balancing network between the receiving relay and the artificial line in order to simulate the composite set. As an additional

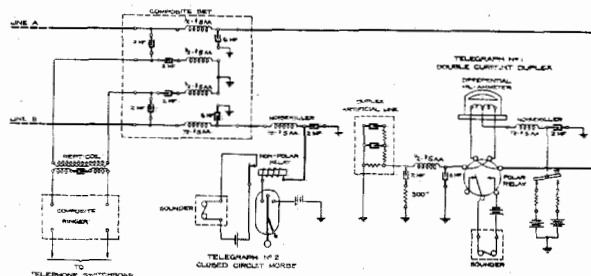

Figure 3—Composite Telephone and Telegraph Circuits. Schematic Diagram

precaution against "Morse Thump," it is required also to insert a "Noisekiller" in the sending legs of the telegraph circuits in order to modify the shape of the signals before they reach the composite set. These features are shown in Figure 3.

For operation over open wire lines, the telegraph currents should not exceed 60 to 65 milliamperes when the batteries at each end of the line are aiding.

On composited loaded telephone circuits a limiting factor upon the allowable telegraph current densities is "Morse flutter." This is the term given to rapid fluctuation in the volume and quality of the speech and is produced by changes in the effective resistance of the loading coils during telegraph signaling.<sup>1</sup>

The magnitude of the flutter depends upon the current density of the telegraph signals, the speed of transmission, the type and spacing of the loading coils, and the length of the circuit. On open wire lines, the loading coils are spaced much further apart than in cables and there is little likelihood of objectionable flutter occurring if the telegraph currents do not ex

<sup>1</sup> "Hysteresis Effects with Varying Superposed Magnetizing Forces," W. Fondiller and W. H. Martin, Transactions A. I. E. E., Vol. XL, 1921, p. 553.

ceed 50 to 55 milliamperes and if the coils are of modern type.

A low current metallic polar duplex telegraph system has been developed recently by the Bell System which is well suited for operating over composited circuits in long small-gauge loaded cables.<sup>2</sup> This system uses a 34-volt battery. The line current, with the batteries at each end aiding, is from 3 to 15 milliamperes, depending on the length of the circuit. A special highly sensitive polar relay ensures trustworthy telegraph operation at these low current densities.

### Telephone Signaling

As ordinary 16 to 20 cycle signaling currents would be diverted by the composite set into the telegraph branch, thus making signaling difficult and interfering with the telegraph, it

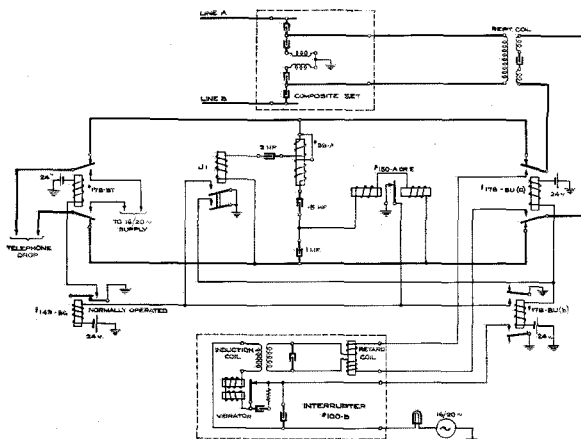

Figure 4—Composite Ringer and 135 Cycle Interrupter

is necessary either to use voice-frequency signaling or else composite ringer sets. The composite ringer comprises a 135-cycle interrupter and a group of switching relays, as indicated in Figure 4. When operated by outgoing 16-cycle ringing current from the telephone switchboard, the composite ringer causes 135-cycle current to be transmitted over the telephone lines, and similarly when operated by incoming 135-cycle current it causes 16-cycle current to be transmitted to the switchboard.

When no signaling currents are being transmitted, the composite ringer provides "through"

<sup>2</sup> "Metallic Polar-Duplex Telegraph System for Long Small-Gauge Cables," John H. Bell, R. B. Shanck and D. E. Branson, Transactions A. I. E. E., Vol. XLIV, 1925, p. 316.

communication via the armatures of the No. 178-BT relay and No. 178-BU (a) relay. The 135-cycle interrupter is then idle.

When the ringing key at the telephone switchboard is operated, the path provided for the 16-20 cycle current is via the armatures of the No. 178-BT relay, and a shunt path tuned to a frequency of 16-20 cycles; i.e., one winding of the No. 99-A retard coil in series with the 2 m.f. condenser and the winding of the No. J-1 relay. The No. J-1 relay operates and provides an earth connection on one side of the two No. 178-BU relays, both of which are energized. The No. 178-BU (b) relay starts the 135-cycle interrupter and short-circuits the contacts of the No. 150-A relay in case the latter is momentarily actuated. The 178-BU (a) relay breaks the "through" circuit and connects the lines to the output side of the interrupter. To prevent false operation of the No. 150-A relay releasing the No. 149-BG relay, the latter is provided with a second earth connection at the contacts of the No. J-1 relay.

The path of the incoming 135-cycle signaling current is via the armatures and back contacts of the No. 178-BU (a) relay and a shunt path tuned to a frequency of 135 cycles; i.e., one winding of the No. 99-A retard coil in series with the 0.5 m.f. condenser and the winding of the No. 150-A relay, which for greater sensitivity is shunted by a 1 m.f. condenser.

The No. 150-A relay releases the No. 149-BG relay, by opening its earth connection, and the latter relay operates the No. 178-BT relay. This breaks the "through" circuit and connects the 16-20 cycle supply to the drop side of the composite ringer so that the usual 16-20 cycle switchboard signaling apparatus is actuated.

To enable all the relays to be operated from a common battery supply, suitable resistances are inserted in the battery leads. Intermediate points are brought out to terminals so that, by appropriate strapping, the composite ringer may be operated at 6 or 24 volts.

The operating range of the composite ringer is determined by the characteristics of the line, the value of the 135-cycle current and the adjustment of the No. 150-A relay. Under normal conditions, satisfactory operation may be obtained over lines in which the attenuation is of the order of 20 TU.

### The No. 100-B Interrupter

The No. 100-B interrupter provides a source of 135-cycle ringing current supply for use with composite ringers in offices too small to justify the installation of motor-generator sets. Its output is approximately 20 milliamperes into an impedance of 1,000 ohms, and one interrupter normally supplies ringing current for five composite ringers.

### Telephone Transmission

The decrease in telephone efficiency caused by compositing is dependent upon the type of

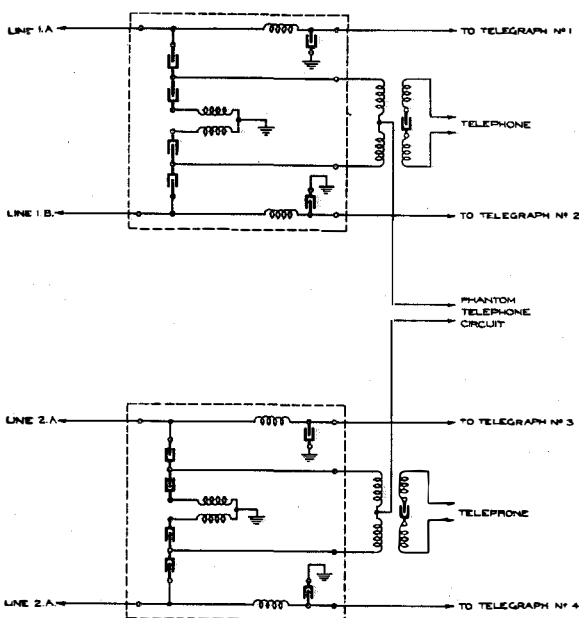

Figure 5—Combined Composite and Phantom Circuits

circuit and the composite apparatus required. On non-loaded circuits requiring only a terminal composite set at each end, the transmission loss is of the order of 1 TU. If two composited circuits are used to provide a phantom telephone circuit, the loss in the phantom circuit will be about 1.5 TU.

The composite ringer causes a transmission loss of approximately 0.1 TU.

The reduction in the transmission efficiency of composited loaded circuits is considerably less than on non-loaded circuits and may be as low as 0.1 TU.

It is not ordinarily considered good practice to composite a phantom telephone circuit, as such an arrangement combines the limitations

of a composited and a simplex superposed circuit. At the same time the compositing of a phantom telephone circuit prevents the compositing of the two physical circuits and thus reduces, from four to two, the possible number of telegraph circuits which can be derived from a quad of conductors.

To preserve the phantom balance it is necessary to equip both of the physical circuits with composite apparatus even when only two earthed telegraph circuits are required.

A combined composite and phantom circuit is shown in Figure 5. To avoid unbalance between the two physical circuits, the condensers in the telephone branches of the composite set are specially selected, and the two windings of each retardation coil are balanced and enclosed in a crosstalk-proof shell. The earthed condensers in the telegraph branch of the composite set prevent any unbalance being caused by differences in impedance between the telegraph circuits.

### Intermediate Composite Sets

The intermediate composite set is especially useful for linking up existing telephone circuits to provide "through" telegraph channels. Figure 6 shows two telephone circuits radiating from one center and providing "through" telegraph facilities between their respective terminals.

The intermediate composite sets may be employed also to by-pass the telegraph around a telephone repeater. It differs from a com-

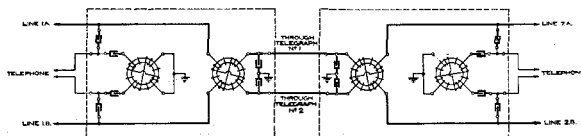

Figure 6—Intermediate Composite Sets, providing "through" telegraph circuits over two separate telephone circuits

posite terminal set only in that the earthed condensers in the telegraph branch have a capacity of 1 m.f. instead of 6 m.f.

### Composite Balancing Sets

Where composited circuits are equipped with telephone repeaters, composite balancing sets are required on the network sides of the telephone repeaters in order to balance the com-

posite sets on the line side of the repeaters. Figure 7 shows a combined terminal or intermediate composite balancing set for use on open wire lines.

Similar balancing sets are provided for use in the balancing networks associated with a

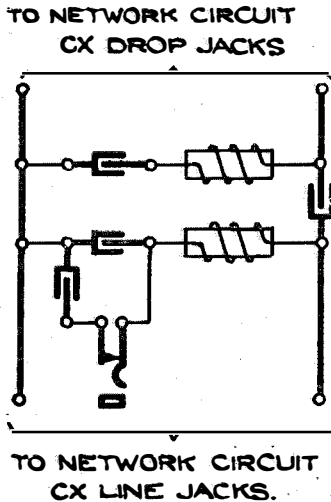

Figure 7—Composite Balancing Set

phantom telephone repeater for balancing the composite sets located in the side circuits.

A balancing set is available also for use where a direct balance of a composite ringer is required.

### **Mounting of Composite Apparatus**

For small or temporary installations, portable composite sets and composite ringers can be provided but, where a number of circuits are composited, it is more economical to mount the apparatus units on racks.

### **Applications and Economies**

Although the fundamental principles of compositing are old in the communication art, it remained for the engineers of the Bell System to develop a system which could be applied readily to long distance telephone circuits without impairing the high grade service obtained.

In America the composite telegraph and telephone system is in daily use on the longest telephone circuits and it has enabled an extensive network of leased telegraph circuits to be built up to meet the requirements of bankers, stockbrokers, and large industrial concerns with offices or plants in different localities.

The American railway companies also make considerable use of the composite system. The economic advantages of combined telephony and telegraphy are such that along some of the large railroads, single wires for telegraph purposes only are scarcely to be seen.

The magnitude of the economies obtainable by the introduction of composite apparatus can best be appreciated by reference to a particular case. As compared with the cost of providing the same telegraph facilities by a single 100-pound 2 mm. copper conductor, the saving by employing composite apparatus in an existing telephone circuit is more than 92 per cent in first cost and 87 per cent in annual charges. In other words, by making use of the composite method, the first cost is less than 8 per cent and annual charges are 13 per cent of the expenditures involved in the provision of a 2 mm. copper conductor for furnishing identical facilities.



# Toll Switchboard No. 3

By J. DAVIDSON

EDITOR'S NOTE: Reprinted by permission from the "Bell System Technical Journal," Volume 6, No. 1, January, 1927.

IN the early days of telephony the toll signaling apparatus consisted of a magnetic drop in the line and a drop or ringer in the cord. With the advent of common battery signaling in the local plant, relays and lamps replaced the old type drops and the subscriber was given means for calling the toll operator on a toll connection by operating the switchhook instead of ringing. Up to this time the toll operators were located at the local switchboard and had direct access to the subscriber's line, but with the growth of toll and local traffic, it was no longer economical to place the toll operators at the local board. This led to the development of a separate toll switchboard called the No. 1 board, which had access to the subscriber's line over switching trunks between the toll and local boards. For many years the No. 1 switchboard filled the needs of the time but with the expansion of the toll service and the growth of machine switching local service, it became evident that new arrangements were desirable. The No. 3 toll switchboard was developed to meet the new requirements and it has the following advantages as new installations are required.

- (a) Reduction in apparatus, resulting in equipment economies.
- (b) Improved maintenance arrangements.
- (c) More readily adapted to modifications required by new operating methods.

In discussing the features of the No. 3 board, frequent comparisons will be made with the No. 1 switchboard to set forth the changes which have been made in the design of the new circuits.

## Main Features

### CORD SIMPLIFIED BY LOCATING SUPERVISORY RELAYS IN LINE AND TRUNK CIRCUITS

The cord circuit of the No. 1 switchboard is equipped with two supervisory relays. One of these relays responds to 20-cycle current and

gives the toll operator a ringing signal, indicating that the distant operator is calling. The second relay responds to direct current received from the switching trunk and gives the operator switchhook supervision of the subscriber. Associated with these two relays are other relays

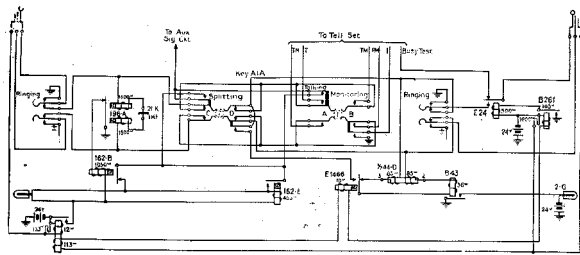

Figure 1—High Impedance Toll Cord for Toll Switchboard No. 1

which prevent false signals, and permit the operator to make a busy test or use the cord for a terminating or a through connection. This cord is shown in Figure 1.

In the No. 3 switchboard the ringing relay and the direct-current supervisory relay, which were formerly connected across the tip and ring conductors of the cord circuit, have been moved from the cord to the line and switching trunk, respectively, and the cord circuit has been simplified as is illustrated in Figure 2. In this board the line and trunk signals are transferred to the cord over the sleeve circuits. This

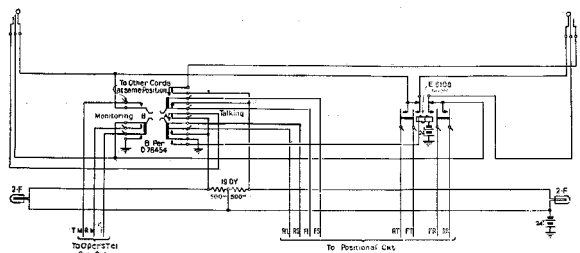

Figure 2—Toll Cord for Toll Switchboard No. 3

is accomplished by using a nominal sleeve resistance of 1,800 ohms for the line and trunk circuits and connecting the lamps in the sleeves of the cord. Under these conditions there is not sufficient current flowing in the sleeve to light the lamp, but when a ringing signal is

received over a line and a cord is associated with that line or when a receiver-on-the-hook signal is received over a switching trunk, the sleeve resistance of the line or trunk is changed from 1,800 ohms to 80 ohms, which increases the current in the sleeve of the cord sufficiently to light the lamp.

LINE RELAY FUNCTIONS IN TWOFOLD CAPACITY

The majority of toll lines in the plant today are of the ringdown type and the operator at one end calls the operator at the distant end by ringing over the line. To receive this ringing signal in the No. 1 board, the lines are equipped with relays which respond to the ringing current received from the distant end of the line and give a line signal. After the operator answers this signal by connecting a cord to the line, the line relay is disconnected and replaced by the ringing relay in the cord which responds to further ringing signals over the line. This arrangement of the line and cord, as well as the switching trunk for the No. 1 board, is shown schematically in Figure 3.

By transferring the ringing relay from the cord to the line in the No. 3 toll board, this relay is made to function in a twofold capacity; that is, to give the line signal as well as the cord ringing signal. When a call is received

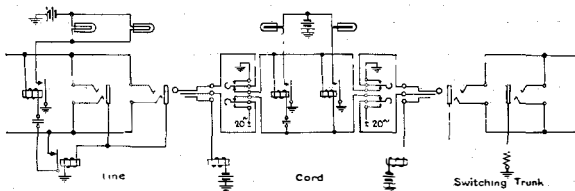

Figure 3—Schematic: Toll Switchboard No. 1 Circuits

from a distant point, the apparatus in the line functions to light the line signal and this remains lighted until a toll cord is inserted in the line jack. Further signals over the line cause the apparatus in the line to light the lamp in the cord. This is obtained by changing the sleeve resistance of the line from 1,800 ohms to 80 ohms and is illustrated in schematic form in Figure 4. As in the past, the line signal is multiplied before several operators and appears as a steady illuminated lamp which is

extinguished by an operator answering the call. The cord signal appears before one operator and has been changed from a steady lamp signal to a flashing signal for the purpose of obtaining prompt attention on the part of the operator. The cord signal is extinguished when the oper-

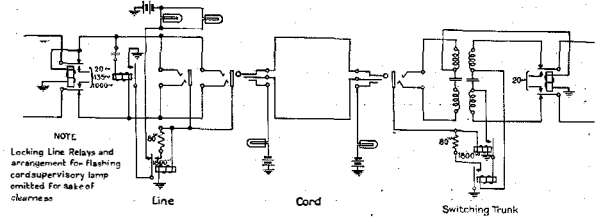

Figure 4—Schematic: Toll Switchboard No. 3 Circuits; monitoring and positional circuit keys are not shown

ator connects to the circuit by the operation of the talking key. This connects an additional 600 ohms in the sleeve circuit, which releases relays which are held operated in the line circuit and control the lamp.

COMPOSITE RINGER SIMPLIFIED

In order that the toll lines may be used for telegraph as well as telephone service, composite sets are often connected into the line circuit at each end. These composite sets are electrical filters which separate the telephone and telegraph currents and direct the telephone currents to the switchboard and the telegraph currents to the telegraph equipment.

When composite sets are connected in the lines terminating in a No. 1 switchboard, it is also necessary to connect a composite ringer in the circuit between the composite set and the switchboard. This is necessary because the 20-cycle current, which is used as ringing current from the switchboard, is in the telegraph range of frequencies and consequently will not pass through the telephone branch of the composite set. The composite ringer substitutes for the 20-cycle outward ringing current received from the switchboard, a higher frequency current which will pass through the telephone path of the composite set. Likewise on incoming ringing signals, the ringer substitutes for the higher frequency current which comes over the line and through the telephone path of the composite set, a 20-cycle current which will operate the ringing relays of the line or cord

circuits. A schematic of the composite set and composite ringer, as used with the No. 1 board, is shown in Figure 5.

In general, the composite ringer for the No. 3 switchboard has been greatly simplified and made a part of the terminating line equipment. This has been accomplished, as illustrated schematically in Figure 4, by arranging the line circuit so that a relay may be cross-connected in the line to receive the 20-cycle, or the higher frequency ringing current, and arranging this relay so that it gives the line signal or the cord supervisory signal direct without going through the step of changing ringing frequencies.

Furthermore, the practice of using 20-cycle current in the cord circuit for ringing has been

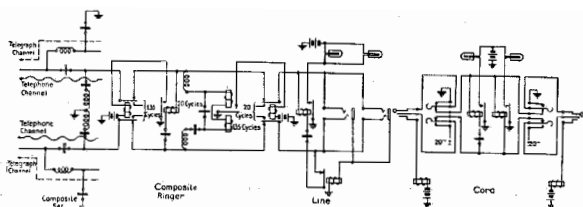

Figure 5—Schematic: Composite Ringer and Compositing Toll Line for Toll Switchboard No. 1

discontinued and ringing is effected in the No. 3 switchboard by connecting 24-volt direct current through the ringing key to the tip conductor of the cord. This current operates a relay of the line or trunk circuit which applies the proper frequency of ringing current to the line or trunk circuit. By this arrangement one relay in the line circuit accomplishes the same result as was accomplished by several relays in the composite ringer. As the ringing current leads to the relay in the line are brought through terminals on the frames, the line can be readily changed for any desired frequency of ringing current.

#### ELIMINATION OF TRANSFER KEY FROM FACE OF INWARD SWITCHBOARD

In the past the practice has been to provide one or two transfer keys per line for each multiple appearance of the line lamp at the inward toll switchboard. The function of these keys is to transfer the inward call from the inward switchboard to the outward delayed positions or to the through positions. With the No. 3 toll switchboard, the use of these transfer keys

individual to the line and appearing in the face of each section of the inward switchboard has been discontinued and the transfer is effected by a transfer key in the positional circuit which may be used to transfer a call on any line. This key applies 24-volt battery either directly

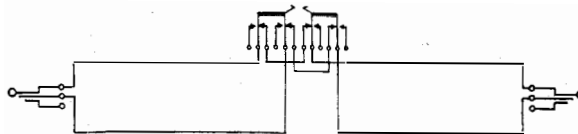

Figure 6—Schematic: Toll Cord Talking Circuit; talking key normal for toll switchboard No. 3

or through a resistance to the ring conductor of the line and operates the proper transfer relay in the toll line and causes lamps individual to that line to light at the outward, or through positions. This feature not only effects a saving in equipment but saves the space in the face of the switchboard which was formerly occupied by the transfer keys.

#### USE OF POSITIONAL CIRCUIT

Another circuit feature of the No. 3 switchboard which marks an improvement over switchboard No. 1 is the use of a so-called positional circuit in which is located much equipment such as splitting keys, dialing keys, etc., which heretofore were individual to each cord. Under normal conditions the tip and ring conductors of the front cord are connected to the tip and ring conductors of the corresponding back cord with no shunts across the circuit. This is illustrated in Figure 6. By the operation of the

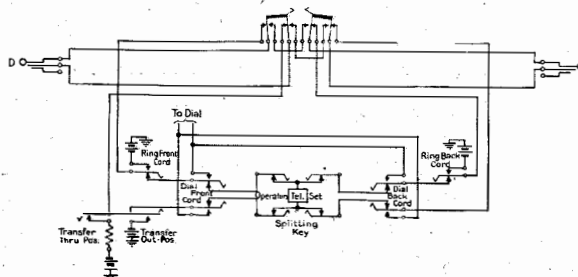

Figure 7—Schematic: Toll Cord Positional Circuit; talking key operated for toll switchboard No. 3

talking key associated with each cord circuit, the positional circuit is connected between the front and back cords and the operator's telephone set is connected across the circuit as illustrated in Figure 7. With the talking key of any cord operated, the operator may:

- (a) Dial on either the front or the back cord.
- (b) Split the talking circuit between the front and the back cords.
- (c) Transfer an inward call from the inward to the outward or the through positions.

This circuit arrangement not only effects substantial economies but it is much more flexible and will lend itself to new developments without requiring changes in the cord circuit.

#### MONITORING AND RINGING KEYS INDIVIDUAL TO CORDS

The monitoring and ringing keys are, as in the past, individual to each cord.

#### SWITCHING TRUNK FEATURES

In the No. 3 toll switchboard a repeating coil which has a high impedance to 20-cycle ringing current is used in the outgoing end of the switching trunk. This arrangement has equipment and signaling advantages. Also where loaded toll switching trunks are involved, the use of a repeating coil of the type referred to, but having the proper transmission characteristics, has the advantage of reducing reflection losses by providing for a uniform terminal impedance of the switching trunks.

#### *Principal Advantages*

##### EQUIPMENT ECONOMIES

As has been pointed out, the expansion in toll business, together with recent developments in the telephone art, have been such that with the circuit arrangements used in the past there has been a growing necessity to add equipment to the cord circuit with the result that the positions are becoming congested with apparatus. With the circuit arrangements outlined for the No. 3 toll switchboard, however, the transfer of the signaling apparatus from the cord to the line and switching trunk makes a marked simplification in the cord and incidentally reduces the congestion in the section. Also it should effect a substantial economy in equipment because of the fact that we are approaching a situation where there are approximately 60 per cent. more cords than lines and 25 per cent. more cords than switching trunks.

The use of the positional circuit and the

elimination of the individual splitting key from the toll cord has simplified the switchboard keyshelf. This simplification together with the equipment savings effected by the simplification of composite ringers and the transfer of the supervisory relay equipment from the toll cord to the toll line and switching trunk circuits has effected substantial economies.

#### MAINTENANCE

In addition to the saving in first cost of equipment the No. 3 switchboard facilitates maintenance. The ordinary toll cords in an office must be suitable to work with any toll line terminating at the switchboard and consequently with the circuit arrangement used in toll switchboard No. 1, the ringing relay in all the toll cord circuits must be maintained to operate in connection with the longest as well as the shortest line circuit. In the case of the No. 3 toll switchboard, however, the ringing relay is individual to the line and consequently may be adjusted to meet the operating conditions of that line. Long lines with severe ringing conditions require the relay to have a sensitive adjustment while short lines with easy ringing conditions permit a less sensitive relay adjustment to be used which is more easily maintained.

#### EASILY ADAPTABLE TO MACHINE SWITCHING METHODS

The introduction of machine switching requires provision for dialing on the trunks and may in the future require the same feature for dialing over toll lines. Such provision in the boards previously employed requires the addition of the necessary keys and relays on a "per cord" basis, whereas with the No. 3 board the equipment can be placed in the positional circuit, without any change in the cord circuit. This results in a great economy in apparatus and makes a change to a dialing basis rather simple.

#### *Summary*

It is interesting to note in conclusion that heretofore an increase in cord circuit apparatus has necessarily followed the development of new

and improved switchboard systems and the extension of the area of long distance communication. For example, the magneto cord with a single drop bridged across the circuit sufficed in the early days of small magneto boards. The advent of the common battery multiple switchboard brought the necessity for extending switchhook supervision to the toll operator, and resulted in the condenser-type cord consisting of 5 relays, now largely abandoned because of the relatively large transmission loss introduced by it. The high-efficiency cord consisting of 8 relays resulted from the demand for a cord having a minimum transmission loss, and additional complications have resulted in the re-

quirement for dialing in machine switching areas, each improvement, of course, increasing the number of relays in the cord circuit. The No. 3 system, on the other hand, makes possible by the transfer of apparatus to the line and switching trunk and by the use of common positional equipment the relatively simple toll cord shown in Figure 2 in which the individual apparatus is limited to two keys and one relay per cord. This provides in many cases a toll cord suitable for either inward, outward or through operation, reduces the apparatus congestion in the section and results in decreased maintenance, while being easily adapted to the future trend in toll development.

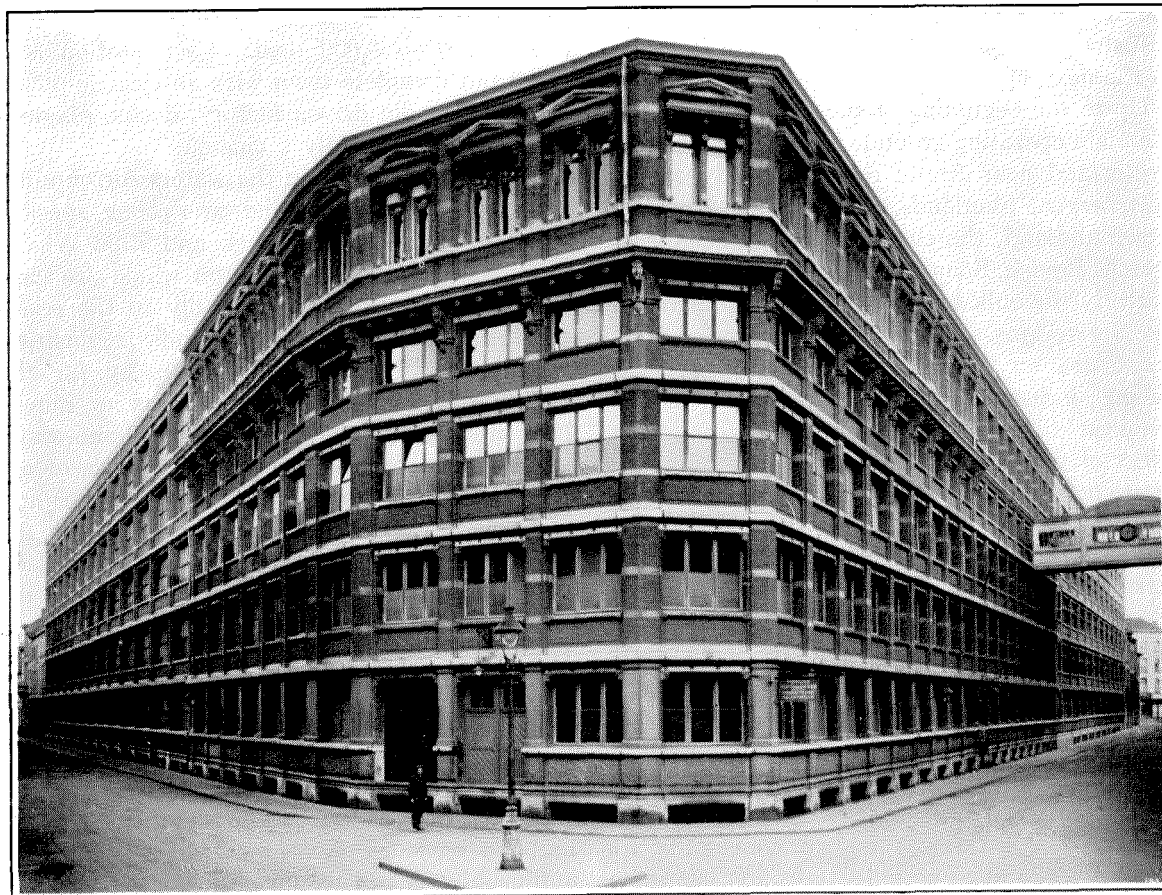

Antwerp Factory of the Bell Telephone Manufacturing Company at the Rue Boudewyns, showing addition completed and fully occupied with productive departments in 1926. The newest portion of the building, providing 117,000 square feet of additional floor space, may be seen beyond the bridge at the right

Construction work on buildings which will provide 140,000 square feet of additional floor space at the Rue Boudewyns was started in the third quarter of last year. Buildings at Hoboken, outside of Antwerp, which will make available a total of 130,000 square feet of floor space also were started or completed in 1926



# Radio Telephony Applied to Antarctic Whale Hunting

By E. A. RATTUE

*Engineering Department, Standard Telephones and Cables, Ltd.*

**T**HE whaling industry dates from the fifteenth century, but it is only within recent years that attention has been turned to the possibilities of radio-telephony as an aid and safeguard to the whaler in his arduous task of hunting in Arctic seas. For four hundred years, operations were carried out from small open boats, entailing grave risks and loss of life. In the year 1863, however, Mr. Svend Foyn of Tonsberg, Norway, built a steamship specially designed and equipped for whaling. Ten years later he invented the harpoon-gun, which, combined with further improvements in the design of whaling vessels, revolutionized the industry. Radio communication has followed as the next epoch-making step in development.

Up to the beginning of the twentieth century the main operating grounds for whaling were the Arctic and near Arctic regions, chiefly around Spitzbergen, Shetlands, Hebrides, Iceland and Newfoundland, the chief participants being the Dutch, French, Spanish, Americans and English. Latterly the bulk of activity has been carried on by Norwegians. Since the Arctic regions also constitute an extensive area for the regular fishing industry, some resentment was felt amongst fishermen, owing to the disturbing effect of whaling on their own operations, and petitions were presented to the governments concerned to prohibit whaling in these regions. This resulted in the Norwegians deciding to seek fresh hunting grounds in the Antarctic where they have established themselves at numerous places, the most notable being South Georgia, South Shetlands, South Orkneys and the Ross Sea.

## ***Antarctic Whaling***

Prior to the Norwegians settling in the Antarctic, very little was known concerning its geographical and climatic features. It has since transpired that the earlier American sealers were aware of the existence of these hunting areas, but because of fear of competition this knowledge was kept a close secret. Evidences of their activities may still be observed at South Georgia

where a number of old blubber boiling pots still lie scattered at various places along the coast. The island (Figure 1) is situated about 900 miles South by East of the Falklands, in latitude 54° South, longitude 36° West; it has an area of about 600 square miles and is mountainous in character with snow-clad peaks rising to a height of 6,000 to 8,000 feet. It is a British possession, politically attached to New Zealand, and is populated almost entirely by Norwegians, who have been engaged in the whaling industry for the past fourteen or fifteen years. They control and operate seven shore whaling stations scattered along its eastern seaboard, and employ from 4,000 to 5,000 men. Each station is a small but complete town with an electric-power supply, a steam driven factory, docks, playing-fields and occasionally a cinema.

The whales caught in the waters surrounding South Georgia are of the whalebone species; namely, the Fin, Humpback and Blue Whale. Occasionally toothed or Sperm whale are captured, but these belong generally to the equatorial oceans. Of the three kinds frequenting the Antarctic, the Blue whale is by far the largest, sometimes measuring eighty or ninety feet in length. An average whalebone-whale will yield twenty-seven to thirty barrels of oil. It is obtained by boiling down the blubber and meat in steam "pressure boilers" while the residue is dried and manufactured into guano. After hydration, the oil is used for margarine and soap making and the guano as a fertilizer. During a season's catch, the output from one factory may reach 80,000 to 90,000 barrels of oil.

To capture a whale, the present method is to fire a harpoon from a gun situated on the bow of a powerful steam whaling craft. A grenade which is screwed on to the spear end of the harpoon explodes on contact inside the whale, and usually causes instantaneous death.

## ***Co-operation in Whale Hunting***

For some time, whaling authorities had realized that whale hunting lacked suitable facilities for co-operation, with resultant excessive and un-

productive steaming and other process work. To improve communications, radio-telegraphy was tried and is still used by some companies, but it was considered that the facilities afforded by radio-telephony might provide a means, without the intervention of a skilled operator,

During 1925, eleven of these equipments were installed in whaling craft in South Georgia and in the South Shetlands. They were supplied by Standard Electric Aktieselskap, Oslo, and were manufactured by Standard Telephones and Cables, Ltd., London.

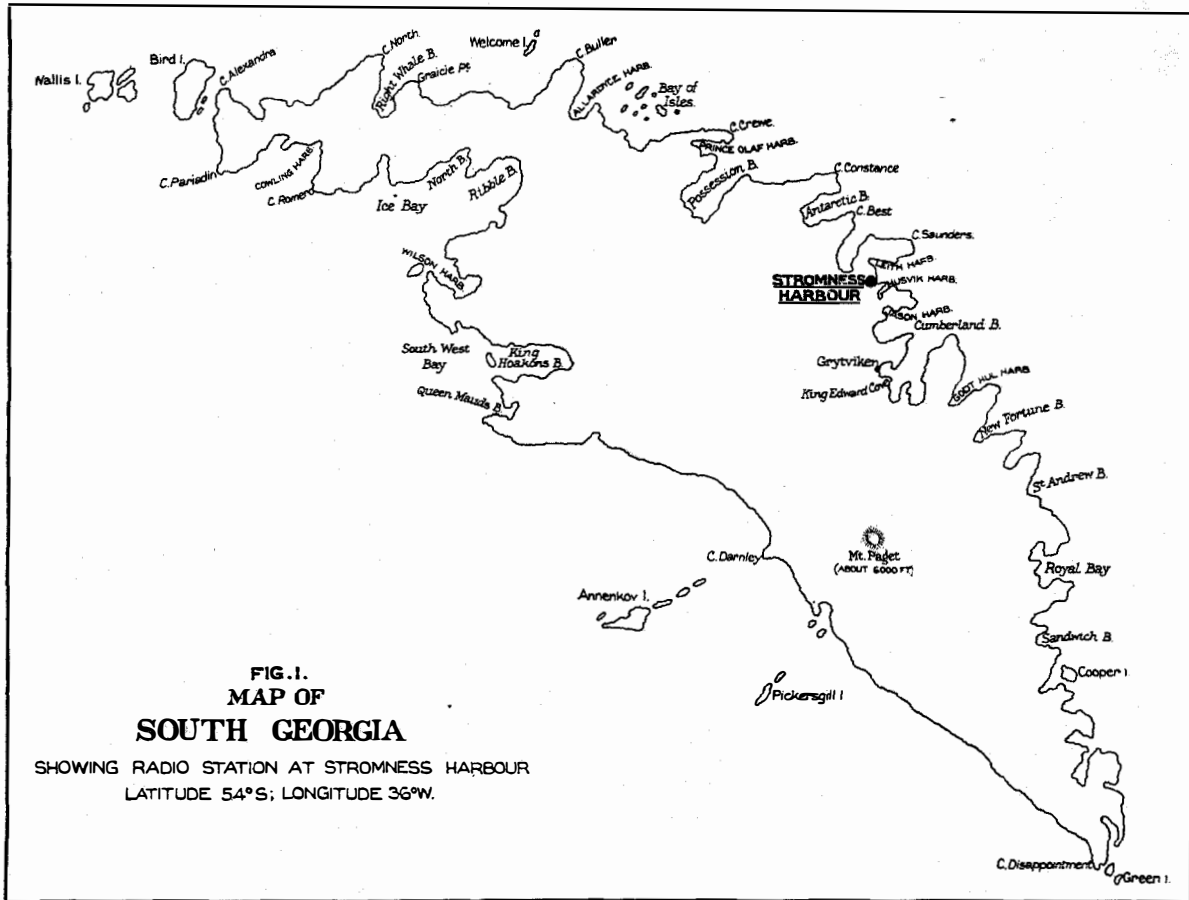

whereby the captain of a whaler could keep in contact constantly with a shore station and with whalers of the same fleet. In order that skilled operators might be dispensed with and a high grade of speech transmission combined with simplicity of operation be obtained, a suitable design of radio telephone-telegraph equipment, comprising the following units, was developed.

- 1—50 Watt Radio Transmitter.
- 1—Subscribers Set.
- 1—Desk Stand Transmitter and Headphones.
- 1—Motor Generator Set.
- 1—Radio Receiving Set.
- 1—Amplifier for Loud Speaker.
- 1—Horn Type Loud Speaker.

The equipment will be considered under the following headings:

- Radio Transmitter.
- Power Unit.
- Receiver, Amplifier and Loud Speaker.

#### **Radio Transmitter**

As may be seen from Figures 2 and 3, the transmitter is built up of panels carrying the apparatus, mounted upon an angle-iron framework 37½" in height, 18" in width and 12" in depth. The overall dimensions of the transmitter are 41½" by 21" by 18" and the weight is 160 pounds.

The back and two sides are closed in with

removable guards of expanded metal. The three lower panels are of sheet steel. The top panel, which carries the aerial tuning inductance and

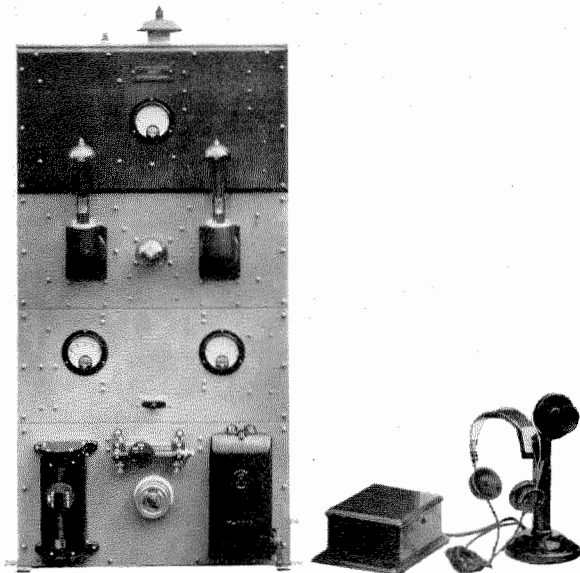

Figure 2—Front View of 50-Watt Radio-Transmitter

aerial ammeter, is of phenol fiber, the use of which avoids losses due to eddy currents and provides high insulation resistance even under severe temperature and humidity conditions. The aerial and receiving terminals are mounted upon a steel panel forming the top of the set, from which they are insulated by means of porcelain insulators. The aerial relay is mounted upon the underside of this steel panel, Figure 3. Immediately below the aerial-circuit panel is a steel panel carrying the oscillator, modulator, and speech-input valves, and beneath it is another steel panel on which are mounted the plate-current milliammeter with its associated key (designated MOD OSC), and the filament voltmeter. The bottom panel carries the power circuits; on the front are mounted the ironclad main switch which also contains the fuses, the three-position snap switch for starting the motor, the motor field rheostat, mounted so that the slide moves from top to bottom, for regulating the speed of the motor, and a generator field rheostat for adjusting the output voltage of the generator. Terminals are mounted upon an ebonite plate fastened on the frame work at the back of the transmitter (Figure 3), with the exception of those for the high-tension circuits

which are mounted inside of the equipment, holes being provided in the terminal plate for introducing the leads from the generator. The maximum voltage on the exposed terminals is limited, therefore, to that of the main supply line. The resistances used in the circuits are of the vitreous enamel protected slip-in type, and are easily replaceable if accidentally injured. For all wiring other than potential supplies and speech input, bare tinned copper wire is used. Potential leads and low-voltage speech-leads are cabled in accordance with normal telephone practice.

The aerial circuit, consisting of the aerial, one set of contacts of the aerial relay, an ammeter, a series condenser, the aerial tuning inductance, and a small tapped condenser, is coupled directly to the plate and grid circuits of the oscillator valve to form a Colpitts circuit for the generation of the high-frequency carrier current. Preliminary tuning is effected by means of the tapped condenser and the final adjustment, by varying the position of the tapping in the aerial tuning inductance. For facilitating this adjustment the ammeter is included in the aerial circuit.

The voice-frequency currents from the desk stand microphones (Figure 2) supplied to the input terminals, are stepped up by the input transformer, amplified by the speech amplifier valve, and fed through the choke capacity coupling to the modulator valve. Modulation takes place in accordance with the Heising or Constant Current System. The plate current for the tubes is obtained from the 800-volt generator through a filter for eliminating commutator noise.

The reduction in voltage necessary for the high-tension supply to the speech amplifier valve, which operates with 350 volts on the plate, is effected by placing a high resistance in the circuit in series with the plate of the valve. A high-frequency choke-coil is also included. A milliammeter and a double-throw key are provided in the connection between the plates of the modulator and oscillator valves. To avoid interrupting the circuit when switching, a make-before-break arrangement is used; the milliammeter is always included in one of the two branches of the circuit. To prevent the high-frequency currents from getting back to the

modulator and from finding a path through the high-tension generator back to earth, and to protect the milliammeter, a protective air choke coil is connected between the oscillator plate circuit and the supply.

The low-tension current is supplied at 12 volts by the direct current generator, the filaments of the valves being connected in parallel. The reduction in voltage for the filament of the speech amplifier vacuum tube which requires only six volts, is obtained by inserting a suitable resistance in the lead.

and speech-input amplifier tubes is obtained by using the potential drop across resistances inserted between the negative high-tension lead and ground. The grid bias for the oscillator is obtained by means of the voltage drop across a resistance inserted between the grid and filament.

Normally the resistance path is completed through an additional resistance of 5,000 ohms which is connected in series with the grid-biasing resistances for the purpose of providing an excessive negative potential on the grids of all the valves, and thereby preventing the circuits from functioning. Accordingly, when transmitting, it is necessary to short-circuit this resistance. To damp out the surge of current through the 5,000-ohms resistance, which occurs whenever the circuit is made or broken, it is shunted with a smaller resistance in series with a condenser.

The telephone-telegraph change-over switch, which is replaced on the later models by a two-way key incorporated in the front panel, performs all the necessary changes in the circuit for operation. When the switch is in the "telephone" position, the arrangement of the circuit is as follows:

- 1 The aerial is normally connected to the receiving set.
- 2 Terminal No. 4 is joined to the negative of the low-tension supply, which is therefore connected:
  - 2.1 Via the switch-hook contacts to the microphone transmitter.
  - 2.2 Via the press-button contacts across the winding of the aerial relay.
- 3 The key terminals are short circuited.
- 4 One side of the 5,000-ohm resistance is connected to the aerial relay.

When the receiver is lifted, current flows through the button of the microphone. On the press-button contact being made, the aerial relay operates, connecting the aerial to the transmitter set, and short-circuiting the 5,000-ohm resistance, thereby permitting the oscillator valve to operate.

A means of calling is provided by a tone-buzzer, connected across the tone terminals, and operated by a tumbler switch.

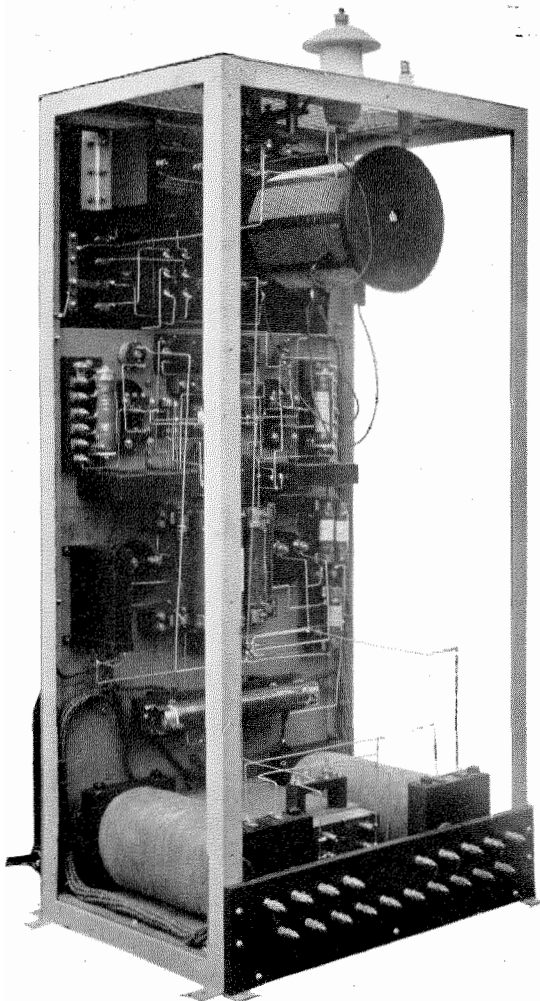

Figure 3—Rear View of 50-Watt Radio-Transmitter with Expanded Metal Sides Removed

A voltmeter is connected across the low-tension leads, enabling the voltage to be adjusted correctly by means of the generator-field rheostat. The correct operating grid bias for the modulator

When the switch is in the "telegraph" position the arrangement of the circuit is as follows:

- 1 The low-tension terminals are connected across the windings of the aerial relay, which operates, connecting the aerial to the transmitting set.
- 2 The Morse key is in circuit.
- 3 The 5,000-ohm resistance is connected across the key terminals.

When the Morse key is depressed the resistance is short-circuited and causes the oscillator

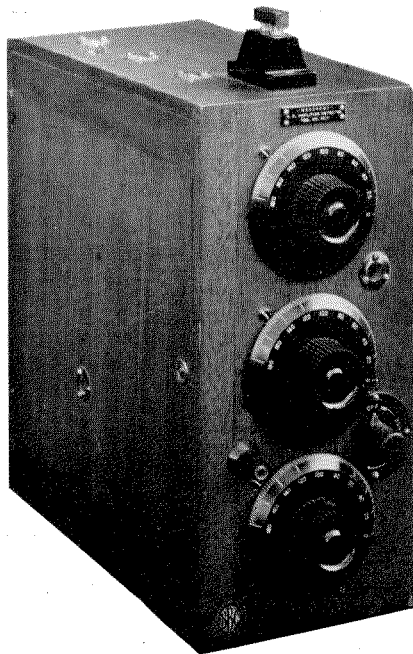

Figure 4—Radio Receiving Set

valve to oscillate. This produces a pure continuous wave. The later models are provided with a means of utilizing either "Tone" or pure wave transmission.

### Power Unit

The power unit consists of a motor-generator set, both machines being totally enclosed. The driving motor is coupled to the generator through a flexible coupling. The generator, which has a double wound armature, delivers 10 amperes at 12 volts, and 0.25 amperes at 800 volts. The low-tension current feeds the filaments, the microphone button, and the relay. The neces-



Figure 5—Radio Telephone Station at Stromness (South Georgia)

sary controlling apparatus is located on the bottom front panel of the transmitting set.

### Receiver, Amplifier and Loud Speaker

The receiving set (Figure 4) contains one stage of high-frequency amplification followed by a tube detector. Aerial and anode tuning is provided, with variable reaction, in the anode circuit of the high-frequency valve. It is well stabilized by the use of small anti-feed-back condensers. The amplifier consists of two stages of low-frequency amplification using three valves, the last two valves being connected in parallel in order to provide sufficient power to operate the loud speaker. The necessary grid-biasing batteries are contained in the amplifier box. Both the receiving set and the amplifier are fitted with Peanut tubes with a filament consumption of 1 volt at 0.25 amperes. All five valves are connected in series to a 6-volt accumulator.

### Installation

#### SHORE STATION AT SOUTH GEORGIA

The first equipment to be installed was at the shore station which is screened badly by high mountains (Figure 5) with the exception of a small outlet to the sea; but despite this screening, no appreciable reduction in range of operation is experienced. The apparatus is housed in a small office adjoining the station-manager's residence, and the necessary power is obtained from the station's power supply.

The earthing system consists of a number of tinned brass pipes soldered together "fan" shape and sunk to a depth of 1 foot 6 inches in very moist soil. The masts and the earthing system were constructed from material available at the station, the masts being of the tripod-semi-lattice type, made of woodspars, bolted together, and strengthened with iron angle

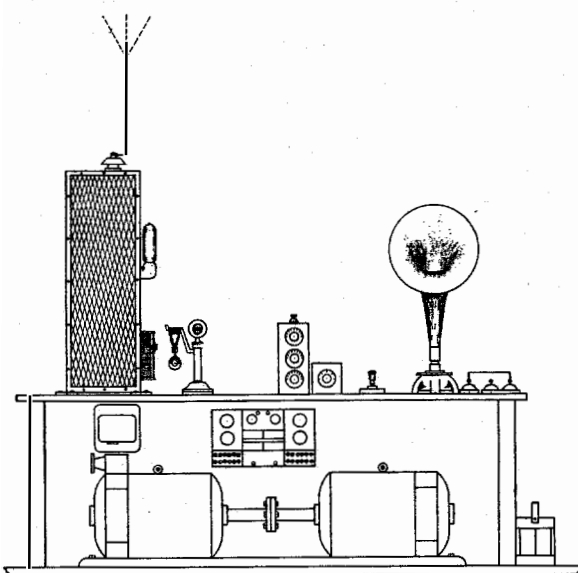

Figure 6—Arrangement of 50-Watt Radio Telephone Equipment in "S. S. Noruna"

plates. Each mast is 65 feet in height and is steadied by four steel cables. The distance between the masts is approximately 150 feet, and the twin "T" type aerial is of 7/18 gauge phosphor bronze wire 140 feet long, separated by 9 foot "Hollow Spar" spreaders, using "Pan" chain insulators. To facilitate the charging of the 6-volt accumulators used in conjunction with the receiving sets on the shore station and whalers a suitable charging panel was installed. High tension supply for the receiving sets is obtained from the main through a suitable filter circuit. The station operates on a wave length of 325 meters, with an aerial radiation corresponding to 40 meter-amperes.

#### ARRANGEMENTS ON WHALERS

Normally a whaler carries only one mast, i.e., a foremast approximately 60 feet high, but the installation of a radio equipment necessitates an

extra mast being fitted, usually a few feet shorter than the foremast. As the distance between these masts is rather short, an inverted "L" type aerial was found to be more suitable than the "T" type. The aerial "lead-in" is taken to an insulator at the aft part of the bridge. This position is most convenient and affords the greatest protection from sea spray. Except for the overall length of 100 to 110 feet and the use of an inverted "L" type aerial, the essential features of the ship aerial system are the same as those of the shore equipment. The apparatus ordinarily is housed either in the chart room, if the vessel is so fitted, or in the captain's cabin. Although the available space is severely limited, a convenient layout (Figure 6) was evolved which harmonized with the cabin fittings and occupied minimum space. When installed in the captain's cabin, the equipment can be accommodated in 8½ square feet of floor space.

As a precaution against movement and vibration, the transmitter, receiver and amplifier, was padded with rubber, and secured to the cabin walls with angle plates. An aerial radiation corresponding to 30 meter-amperes was obtained from each vessel's equipment.

Tests carried out between the whalers and the shore station showed that good two-way com-

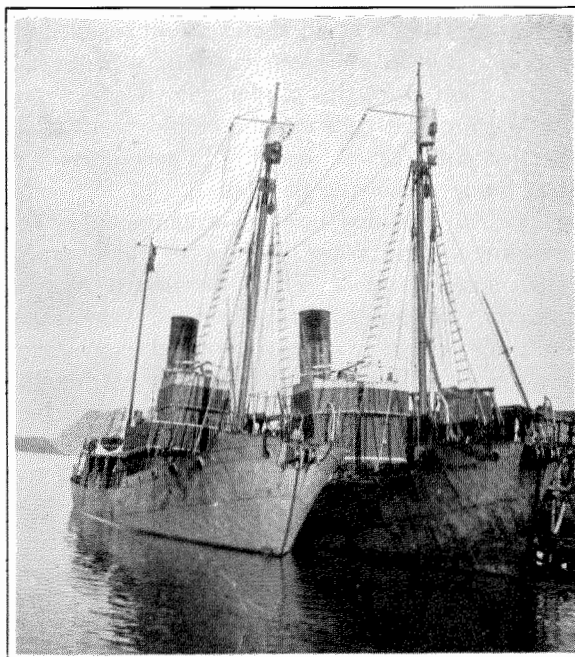

Figure 7—Whaling Vessels Showing Aerial System



munication at loud-speaker strength can be maintained up to 100 to 120 miles daylight range, provided the vessel is from 8 to 10 miles clear of the land and is using a 325 meter wave length. Reception is remarkably free from interference from commercial ship working, except at very close range. Tuning is reasonably sharp, and although the vibration from the vessel's engines, and rolling, was at times rather bad, the receiver was free from microphonic noises.

### ***Operating Conditions***

During the Antarctic summer season it is usually possible to obtain good communication at long ranges, but the winter with its practically unceasing storms of snow and sleet, accompanied by severe atmospheric, at times renders communication almost impossible. Even during the summer, snow and sleet storms, though less violent, are prevalent, and the snow adhering to the insulators of the aerial system is a constant source of aerial-current leakage.

The great difference existing between the temperature outdoors and that of the steam heated room containing the equipment is very liable to cause excessive sweating, which is detrimental to the efficient operation of the radio apparatus. The tropical finish given to the transmitting set and the excellent insulating material used in the construction, were sufficient to counteract this tendency.

Whale hunting calls for the employment of a specially constructed vessel. It resembles an ocean going steam-tug of from 120 to 180 tons net, with a modified bow to accommodate the harpoon-gun and ropes. Some of these craft are seen in Figure 7. From the nature of the work, they are subjected to very heavy weather conditions, and it is quite a common experience for a vessel to roll 40 to 50 degrees. Although some slight variations due to this cause may be noticed when using unmodulated continuous waves, the effect on telephony, even at maximum range, has been found negligible. The rolling of the ship, combined with the shocks experienced when the harpoon-gun is fired, set

up a heavy vibration, but by taking suitable precautions in the installing of the equipment, trouble from this source was reduced.

### ***Advantages of Radio Telephony***

Results obtained from the employment of radio telephony in the whaling industry have proved that it promotes co-operation in hunting and in conveying information concerning weather conditions and fishing prospects in other areas. Moreover, it enables messages to be sent to the shore station giving information on subjects such as provisions, coal, repairs and renewals needed on arrival, thus effecting considerable saving of time and ensuring quick dispatch. Its aid in cases of distress may prevent disaster and, as whalers hunt for the most part in imperfectly charted waters, it constitutes a valuable safeguard to life at sea.

Radio telephony, as applied to whale hunting at South Georgia, has justified its adoption thoroughly. Like radio telegraphy, it is non-secret, but this is easily overcome by the use of a suitable code. Many instances have occurred in which a whaler has sighted a large school of whales and, by use of the telephone, has enabled other vessels of the fleet to obtain an exceedingly good catch. On one occasion, a certain whaler had the misfortune to damage an engine cylinder top and lay drifting helplessly at the mercy of wind and tide. A call for assistance was broadcast and picked up by another vessel of the fleet, which went to her assistance and towed her safely into port. Meanwhile, details of the trouble were passed on to the shore station where speedy preparations were made for casting a new cylinder top and, within a short time after arrival, the vessel was again able to proceed to sea and to resume operations. Throughout the season, the equipment has rendered constant service, the particular instances just quoted being typical of the work on which it was employed. Reports received from representative sources show that the output of whale oil since the adoption of radio telephony has increased in a most satisfactory manner.

---

# Iceland and Its First Broadcasting Station

By KEITH H. THOW

*Engineering Department, Standard Telephones and Cables, Ltd.*

THE Reykjavik broadcasting station, a Western Electric type 1-A, 500-watt equipment, is similar to the one installed at Birmingham.<sup>1</sup> It was supplied by Standard Electric Aktieselskap, Oslo, and officially opened in April, 1926.

Reykjavik, the capital of Iceland, numbers about 21,000 inhabitants. The total population of the country, including the Westmann Isles, approximates 99,000. The map, Figure 1, shows the geographical features and the location of the more important towns, and gives an idea of the distribution of the people. As indicated in the figure, all the important centers of population along the coast are connected by telephone and telegraph lines. Reykjavik alone has nearly 2,000 telephones, the system

<sup>1</sup>"The Birmingham Broadcasting Station," A. E. Thompson, *ELECTRICAL COMMUNICATION*, Vol. 2, No. 3, January, 1924.

in use being local battery with magneto ringing. Since the overhead lines are damaged frequently by violent storms, they are gradually being replaced by underground cables.

All the towns are situated on or very near the coast mainly because the staple industry of the country is fishing. The interior is utterly barren and desolate, including as it does volcanic mountains (mostly extinct), glaciers and lava fields. The climate of the coastal regions is comparatively mild for such high latitudes, owing to the influence of the Gulf Stream, but the interior is perpetually covered with ice and snow. When the Panama Canal was completed, a marked change for the better was noticed in the climate due to the deflection of the Gulf Stream at its origin so that it now runs further north than formerly. In Reykjavik, the average temperature for the year is 39° F.

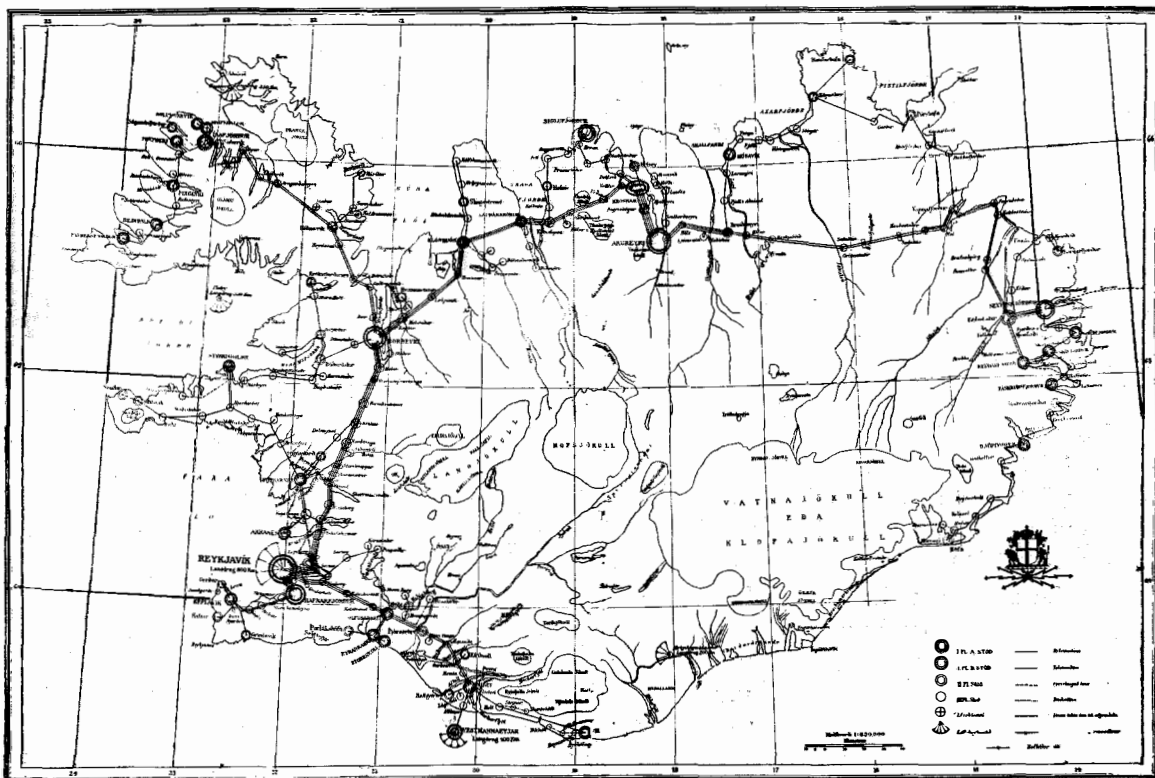

Figure 1—Map of Iceland

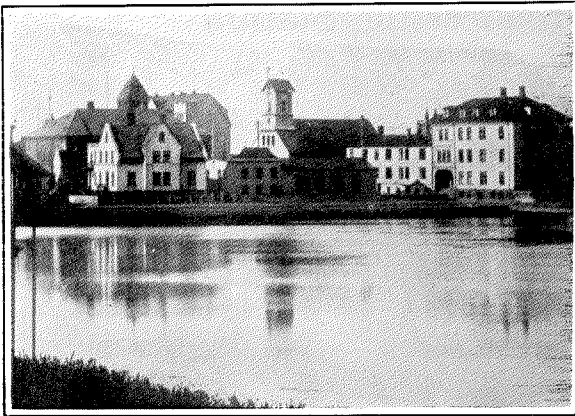

Figure 2—Reykjavik—Lake and Buildings

and the average weather is wind and rain. Apparently during the writer's two months' stay the weather was exceptional inasmuch as the lake in the town (Figure 2) was frozen to a depth of 12 to 18 inches practically the whole time, and about the middle of December there were 2 or 3 inches of ice around the edge of the harbor.

In December, 1924, the Steamer "Lagarfoss" was compelled to lie outside of Reykjavik Harbor (Figure 3) for 30 hours with two anchors out and going full steam ahead (equivalent to 13 knots in calm weather) to avoid being driven ashore by a shrieking hurricane of 100 miles an hour. The hardest frost recorded in recent years occurred in December, 1918, when the temperature reached 16.5° F. This lasted for several days, fortunately without wind, and the whole harbor was frozen more than a foot deep. On account of the rigors of the climate and the absence of roads, travel into the interior is confined to the summer months and even then is carried out almost entirely on the wonderfully surefooted Iceland ponies. These little beasts can be galloped on smooth ice with perfect safety, and the Icelanders jokingly claim that they can be ridden backwards down a ladder.

As will be seen from Figures 4 and 5, some of the scenery is very beautiful though of a somewhat severe character. The whole country is volcanic and the total area of over 100,000 square kilometres is divided roughly as follows:

Glaciers or perpetual ice and snow.....13,000 Sq. Km.

Other high-lands or mountainous regions.....70,000 Sq. Km.  
Post-glacial lava fields.....11,000 Sq. Km.  
Lowlands..... 7,000 Sq. Km.

Vatnajokull, the largest glacier in Iceland, has an area of more than 8,000 sq. km. and reaches a height of 2,119 metres. There are 130 volcanoes known in the country, of which 25 have erupted in historic times; Hekla is the best known and most destructive, having erupted 18 times between 1104. and 1845 A.D. The last volcano to erupt was Katla, in 1918, which was the fourteenth time it had been active since the year 900. Hot springs, both of warm and boiling water, are found in every part of the island and at all altitudes. Great Geysir has not been active for several years, but some of the smaller springs in its vicinity usually can be made to spout if baited with soap.

Several of the Iceland rivers rank among the best in Europe for salmon and, to a lesser extent, for char and trout fishing. The total



Figure 3—Reykjavik Harbour

amount of water-power available is estimated at 4,000,000 H.P. but so far very little is used. Reykjavik is supplied with three-phase alternating current at 220 volts, 50 cycles, for lighting and power. At present, however, the service is not very satisfactory inasmuch as the waterfall, located a few miles outside of the town, from which the power is generated, is quite small and, when the temperature falls appreciably below the freezing point, ice crystals choke the grilles used to prevent stones, etc., from getting into the turbines, thus cutting off

the water supply and reducing the power in many cases to zero. When this occurs, everything, including broadcasting, is brought to a standstill except such business as can be carried on by candle-light.

During winter, an emergency gang is kept in readiness for a frost when, fortified with large quantities of coffee, the men manage to maintain a reduced power supply by scraping off the ice crystals as they collect on the grilles.

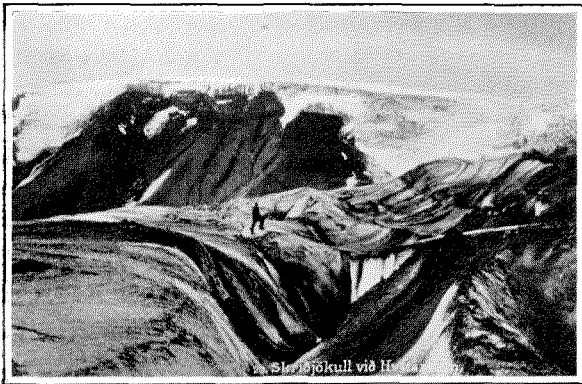

Figure 4—Glacier and Mountain Scenery

It is planned to heat them electrically, using 40 K.V.A. of the plant's output, to a temperature sufficient to prevent adherence of the ice crystals. In the town, it is standard practice to replace the 220 by 110 volt lamps when the power supply drops and, as these are frequently forgotten when the supply again reaches normal, it would seem that the sale of the higher voltage lamp should be much larger than that of the lower voltage.

There are five commercial radio-telegraph stations in the country, the chief one being at Reykjavik. This station has two spark transmitters, one working on 2 K.W. (rotary spark gap) for 600 metre traffic, the other working on 5 K.W. (rotary converter) for 1,800 metre traffic with Greeland, Bergen and, under favorable conditions, with Stonehaven. The station building is of reinforced concrete and is very well equipped with all conveniences, including central heating. A plan of the main floor is seen in Figure 6 which gives a good idea of the arrangement of rooms and layout of apparatus. An exterior view of the building is shown in Figure 7 and a sketch of the aerial arrangements in Figure 8.

Owing to the impossibility of erecting buildings and masts during the winter months on account of frosts and storms, permission was obtained to install the broadcasting equipment temporarily in one of the spare rooms at the Reykjavik radio station and also to sling the aerial to one of the 250-foot masts. The actual installation presented no outstanding difficulties, the chief troubles being due to rough weather and the difficulties of obtaining materials and labor. The presence of the 600 and 1,800 metre aerials necessitated the erection of a sloping cage aerial for broadcasting purposes. The upper portion consisted of a six-wire cage 120 feet long on three heavy iron hoops five feet in diameter and the lower portion of a four-wire cage 180 feet long on hoops nine inches in diameter. While awaiting the arrival of suitable wire from Denmark, a temporary aerial was made up to similar dimensions but of 7/22's wire instead of 7/18's as designed. This aerial broke in half in an 80 mile gale after withstanding the strain for twenty minutes. The top portion of the cage, 120 feet long and weighing over two hundredweight, was swung out almost horizontally from the top of the mast; meanwhile the lower portion came down across the overhead power lines leading into the radio station. All the fuses in the lines blew out, with the result that the radio station had to resort to the emergency 110 volt accumulator battery for light and transmission for several hours before the damage could be repaired. Owing to very severe weather, the permanent aerial was not completed until five days later, by which time the new wire had arrived.

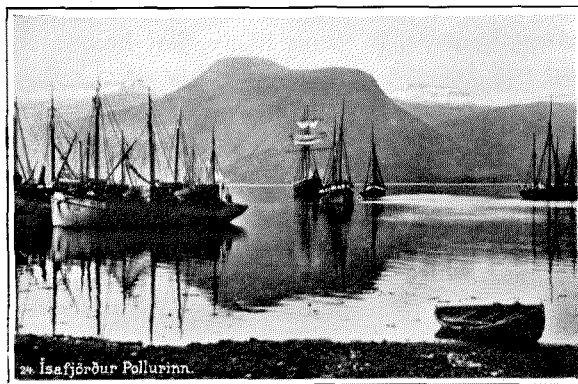

Figure 5—A Harbour on the North Coast

No announcements had been made of the date and time of the preliminary adjusting and testing of the broadcasting equipment, but these were picked up by various people who already possessed receivers. News spreads so

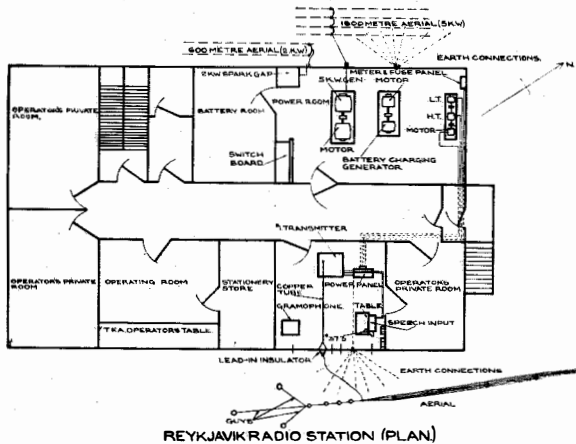

Figure 6—Reykjavik Radio Station—Plan of Main Floor

rapidly in a small town like Reykjavik that everyone had heard of the tests within a few hours, and over a hundred crystal sets were sold in the town next day.

With the exception of two cinema theatres, the only entertainments in Reykjavik are occasional concerts, by amateur choral societies, bands or orchestras, and dances. As a consequence, all entertainments are very well patronized and the installation of the broadcasting station with its promise of a new form of amusement aroused great interest among the Icelanders. In fact, with all the disadvantages of severe climatic conditions, isolation of towns and villages, difficulties of travel, and lack of entertainments, it seems likely that broadcasting will become of greater utility as a public service in Iceland than in any other European country.

Reception conditions are not good in Iceland, partly because of its mountainous nature, but mainly because of the atmospheric disturbances accompanying the Aurora Borealis. When there is a really good display of "Northern Lights" radio reception is impossible, as nothing can be heard but a continuous roar like escaping steam, and in consequence their beauty is not appreciated by a radio enthusiast. Under rea-

sonable atmospheric conditions, Daventry can be heard during the winter months at loud-speaker strength with a four valve receiver, although the signal strength may vary in an extraordinary manner during the evening. For example the writer found on seven or eight different evenings that the signal strength from Daventry was good from 1700—1900 G.M.T.,<sup>2</sup> faded, almost completely, at times from 1900—2100 G.M.T. and then came in well again from 2100 G.M.T. until the station closed down. Results from the short-wave British broadcasting stations are very poor, necessitating such a powerful set that the results do not justify the expense involved, as the ratio of noise to signal strength is excessive. The best of the short-wave British stations heard by the writer was Bournemouth and not one of the nearer stations as might have been expected. Interference from Reykjavik radio, Call Sign "T. F. A.," is quite unavoidable, and equally serious on all wave lengths, whether the 600 or 1,800 metres spark set is in use, as the station is only about a mile from the centre of the town. Fortunately arrangements have been made for the station to be closed down during broadcast hours (ship traffic then being handled by the Westmann Isles); interference from trawlers is also considerably reduced, as the

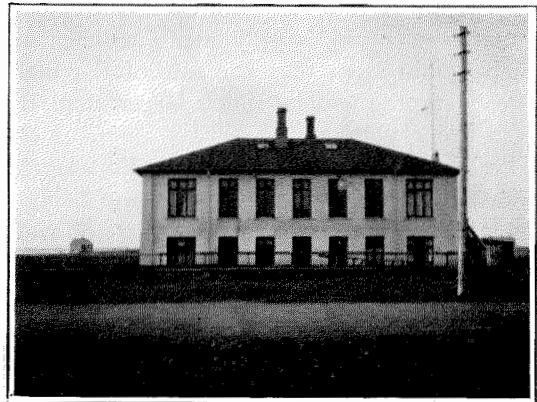
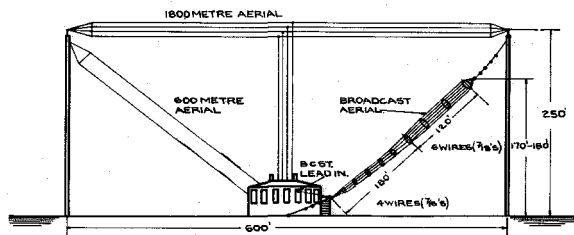

Figure 7—Radio Station Building

crews of most of them listen to the broadcast programme unless there is something urgent to transmit.

Reception conditions during the summer  
<sup>2</sup> Iceland time is 1 hour later than Greenwich Mean Time.

months are very bad indeed; no short-wave stations are audible except at rare intervals, and even Daventry only comes in very faintly.



AERIALS AT REYKJAVIK RADIO STATION.

Figure 8—Radio Station Aerials

The most northerly point of Iceland, Cape Horn, is just within the Arctic Circle, but even on the South Coast there is practically uninterrupted daylight during the months of June, July and August. This probably is the explanation of the poor summer results.

During preliminary tests the transmitter room was used as a temporary studio while arrangements were being made for the permanent studio in the centre of the town. Connections between the radio station and the studio will be made by means of five pairs of wires, set aside for the purpose in an underground cable. It is possible that the studio will always be remote from the transmitter, as there is a scheme under consideration to replace the existing commercial spark transmitters by a 5 K.W. valve set which could be used, say, for four hours daily for broadcasting and for the remaining twenty hours as a C.W. (continuous wave) telegraph transmitter. If this scheme materializes, the studio will certainly be situated in the town, for the convenience of artists; and all volume control will be done from the studio—the operator using a small receiving set for monitoring purposes. Under these conditions, outside broadcasts from the Cathedral, Parliament, hotels, etc., will be connected to the radio station by means of the control equipment in the permanent studio.

In the absence of professional artists in Iceland (except for occasional visitors) the programmes of necessity will be supplied by amateur talent. Reykjavik, however, is fortunate in having two or three excellent male voice and mixed choral societies in addition to a

number of talented soloists. On the instrumental side, there are amateur brass bands and orchestras, and it is proposed also to broadcast dance music by the small orchestras playing at the chief hotel and cafe in the town. The education level in the country is very high, and in consequence lectures on subjects of real interest by professors of the various colleges, Members of Parliament, and others, are assured of good reception. It is proposed also to broadcast services from the Cathedral (Figure 9). This should be very much appreciated by the public as the Cathedral is invariably packed to suffocation at least an hour before the service commences, and numbers of people who are unable to gain admission would welcome the opportunity of listening in by radio.

In connection with the broadcasting of church services, an interesting and very successful experiment was carried out on Sunday, January 31, 1926. On this occasion the annual service for "Those in Peril on the Sea" was held in a church at Hafnarfjord about 8 miles by road from Reykjavik. By special request arrangements were made to broadcast this service for the benefit of large numbers of trawlers at sea. The microphone (of the double button carbon type) was installed on the pulpit in the church and three overhead bare wires were run from it to the telephone exchange about 100 yards away, in which the speech-amplifier and volume-control apparatus had been installed. Connection was made between the Hafnarfjord and Reykjavik telephone exchanges by means of overhead trunk lines; these were iron wires, and the pair used had a resistance of 140 ohms, which necessitated full amplification on the



Figure 9—Reykjavik Cathedral and Althing House



volume control. Connection between Reykjavik exchange and the radio transmitter was made through one of the five pairs in the underground cable previously mentioned. During the preliminary tests, considerable interference was picked up from overhead direct current power lines close to the microphone leads; this difficulty was easily overcome as the power was shut off during the service. The transmission was received and greatly appreciated by a large number of trawlers at distances up to 300 miles and in all cases the speech was reported as excellent, indicating that the quality had not suffered appreciably through the land-line transmission and exchange cord circuits.

The Iceland Broadcasting Company has a capital of 100,000 Icelandic Kronur,<sup>3</sup> 60,000 Kronur having been subscribed by six prominent trawler owners and business men in Reykjavik who also formed the Board of Directors. The remaining 40,000 Kronur was offered for general public subscription.

The revenue of the Broadcasting Company is derived from an annual license fee of 50 Kronur,<sup>3</sup> a royalty of 85 Kronur on all receive-

<sup>3</sup> In December, 1925, the rate of exchange was 22.15 Icelandic Kronur to the pound Sterling.

ing sets sold (irrespective of type, size or price) and also on certain component parts. The royalty on headphones and transformers is 5 Kronur; on valves, 2 Kronur; and on loud speakers, 20 per cent of the retail price. In addition the Company is exempt from the import duty of 15 per cent ad valorem (previous to March 1, 1926, 20 per cent) which other radio dealers are required to pay, so that, under its concessions from the Government, it has an almost complete monopoly of the country's radio business.

Curiously enough, practically all the members of the public with whom the writer came in contact expressed a strong desire that Daven-try's programmes, in particular dance music by the Savoy Bands, should be relayed from the Reykjavik station as often as possible in preference to local programmes. Arrangements will be made to meet this demand as often as atmospheric conditions permit. One or two of the Swedish and German broadcasting stations are heard occasionally, but reception from them is unsatisfactory even during the winter months.

The writer found the Icelanders extremely hospitable. They did their utmost to make his stay in their country most pleasant.

## Some Features of the Long Distance Telephony Exhibition in Paris

29th November—6th December, 1926

**T**HE exhibition, organized in Paris at the close of last year by the Comité Consultatif International des Communications Téléphoniques à Grande Distance, directed attention at an appropriate moment to international telephony and to the benefits to be derived from long distance working across

tories, each with its own geographical characteristics, its own economic outlook, its own telephone administration, and its own ideals, presents problems to telephone engineers and to governments that require in a high degree the combined influences of technical skill, foresight and acumen.



Figure 1—Comité Consultatif International des Communications Téléphoniques à Grande Distance Exhibition.  
View towards the Test Desk

the various frontiers of Europe. The history of telephony, within individual countries, usually has been a story of development from comparatively short local lines to systems involving aerial lines extending to territorial limits, but rarely beyond them. At the stage now reached, however, it is necessary to provide for systems traversing all borders. In this respect, Europe with about twenty-eight self-governed terri-

It was realized a few years ago that the cooperation which has been in evidence from time to time among various telegraph administrations in Europe ought to be established as well as strengthened and made more intimate in the case of telephony; for the linking-up of telephone systems demands not only standardization of methods and of apparatus, but complete unanimity concerning technical and traffic

problems. Mr. Frank Gill, in his inaugural address as President of the Institution of Electrical Engineers (London), on November 2, 1922, speaking with reference to the development of the through business both within and between the countries of Europe by long lines,

Early in 1923, at the direct invitation of France, there was formed a Preliminary Technical Committee, consisting of representatives of certain European Telephone Administrations. This committee ultimately became the Comité Consultatif International des Communications



Figure 2—General View of Exhibition Looking Towards the Exit

recommended that the telephone-operating authorities of Europe,

“should hold an early conference of all the telephone authorities, companies and municipalities as well as Government departments, to study in detail this problem and endeavor to find a solution.” He added, he was convinced that, “unity of control over the through traffic must obtain in the end, but whether the through traffic is handled by one organization or by many, there are matters which urgently require agreement for the improvement of telephony as an efficient agent for service in Europe.”<sup>1</sup>

<sup>1</sup> “The Future of Long Distance Telephony in Europe,” by Frank Gill, *ELECTRICAL COMMUNICATION*, Vol. 1, No. 2, November, 1922.

Téléphoniques à Grande Distance (“C. C. I.”). It decided to invite representatives of the telephone industry to co-operate by contributing to the discussions. The Committee now consists of delegates from twenty-five European countries, together with a number of experts representing manufacturers—altogether about one hundred members. Problems are dealt with in detail by special sub-committees formed from the members, and there is a general assembly every year, usually in Paris, to consider the work of the sub-committees.

Several meetings of this Committee have now been held, and excellent work has been done in the study of such matters as specifications, the steps to be taken to prevent inductive interference on long lines and the most efficient traffic methods. The conclusions take

the form of recommendations to administrations.

It was decided that the work of the Committee would be assisted if delegates were given an opportunity to study from time to time the latest apparatus designed by different companies, and consequently arrangements were

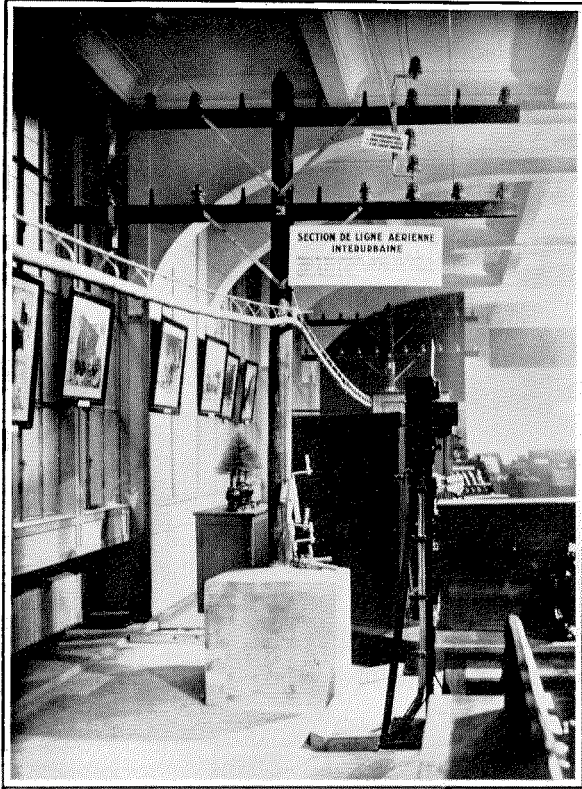

Figure 3—American Tenpin Arm Aerial Construction of Open Wire Lines. Poles also shown carrying aerial cable

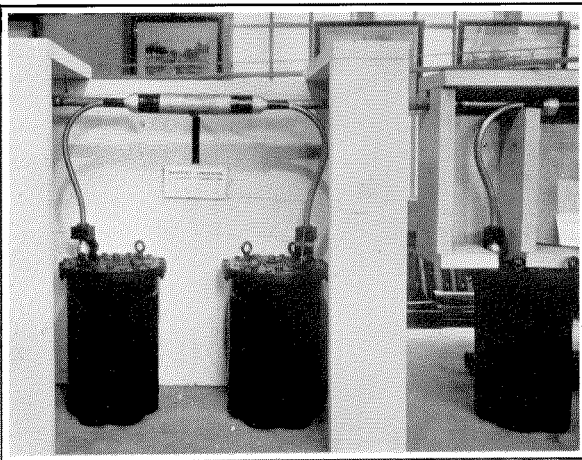

Figure 4--Loading-pot Manhole and Joint

made for an exhibition to be held in November—December, 1926. Manufacturers and administrations were asked to exhibit and to demonstrate equipment relating to long distance telephone communication. This invitation was accepted by the British, French and German Administrations, as well as by several British, French and German manufacturers, and the exhibition took place at 27 rue Guyot, Paris—a new building, which is to house a Rotary System automatic exchange.

The exhibits of the International Standard Electric Corporation and of Le Matériel Téléphonique—the local Company holding the French patent rights of that Corporation—occupied space on the ground floor (see Figures 1 and 2).

The entire length of the hall on one side was occupied by line-plant, which demonstrated International Standard Electric Corporation pole-line methods as well as existing practices relating to underground cables, loading pots, etc. The aerial line exhibited represented Bell Tele-

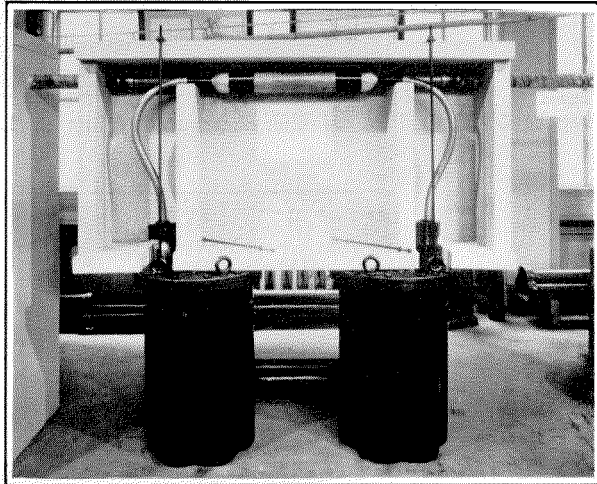

Figure 5—Concrete Box Manhole, illustrating method of burying pots while the joint is protected by a concrete box

phone System practice, which the Compañía Telefónica Nacional de España has adopted for its long lines construction between important points in Spain. Four poles were set up on brick and cement plinths, each pole carrying two 10-wire cross arms. An aerial cable, about  $1\frac{3}{4}$  inch diameter, was suspended by Bonita rings from a steel cable fixed to these poles. The exhibit

was arranged to show the construction adopted in special circumstances. The standard American type of glass insulators was used and, as depicted in Figure 3, one pole was equipped with pair and quad transposition fittings. The aerial lines were led off the poles at each end by weatherproof wire and the aerial cable was led through samples of crutch joints into terminal boxes—at one end a No. 18 type, at the

other end a "B" type box. From the "B" type box an insulating joint to an underground cable was made, while the No. 18 type box showed the method of connecting aerial cable to open wire lines of high quality. The steel cable supporting the aerial cable, for illustrative purposes, was false dead ended at one end. Elsewhere grade clamps, hemp suspensions, and other details were shown.

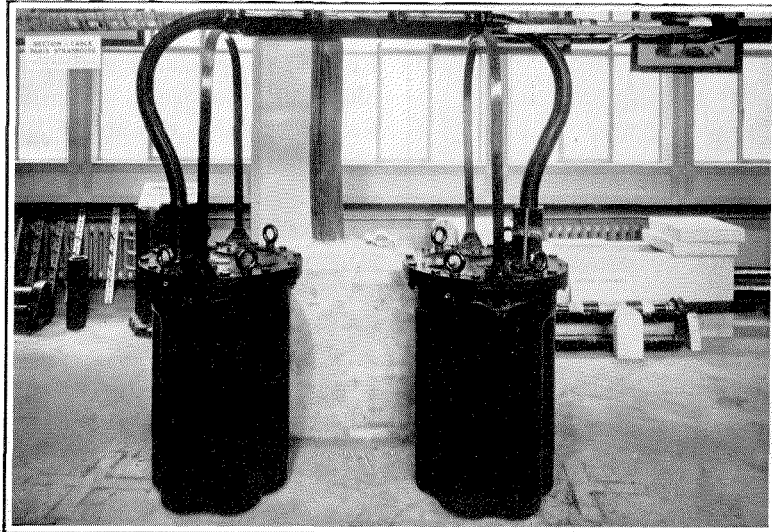

Figure 6—Method of Making Armoured Joints at Loading-point. Intended for use in tropical countries

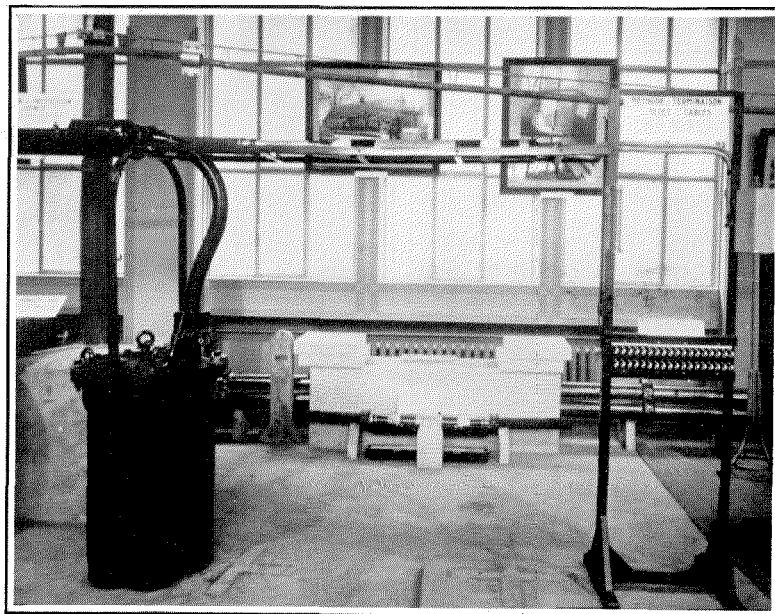

Figure 7—In the Foreground is Shown a Cable Pothead and Three Types of Cable Terminations. In the Background, a Demonstration Cable-joint on a Duct Line



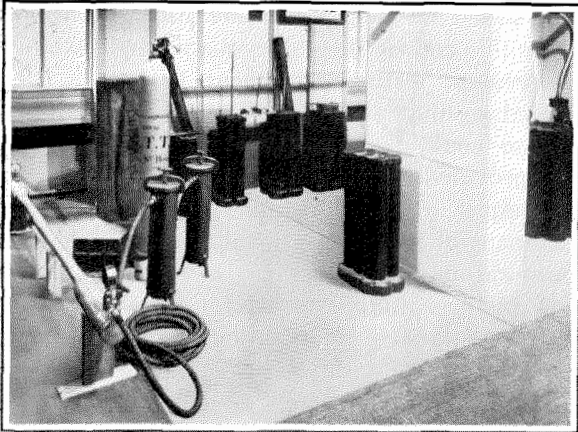

Figure 8—Cable Pressure Testing Gear and Different Types of Ducts

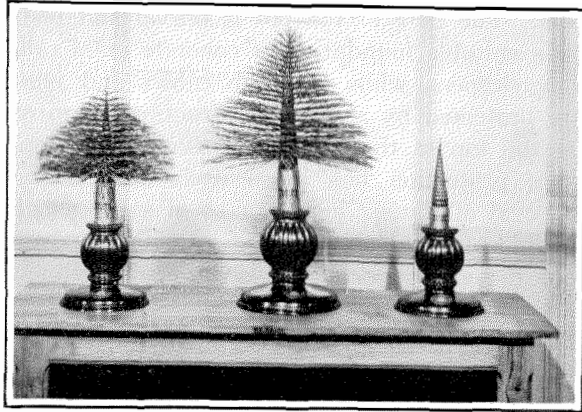

Figure 10—Exhibits of Local Cable

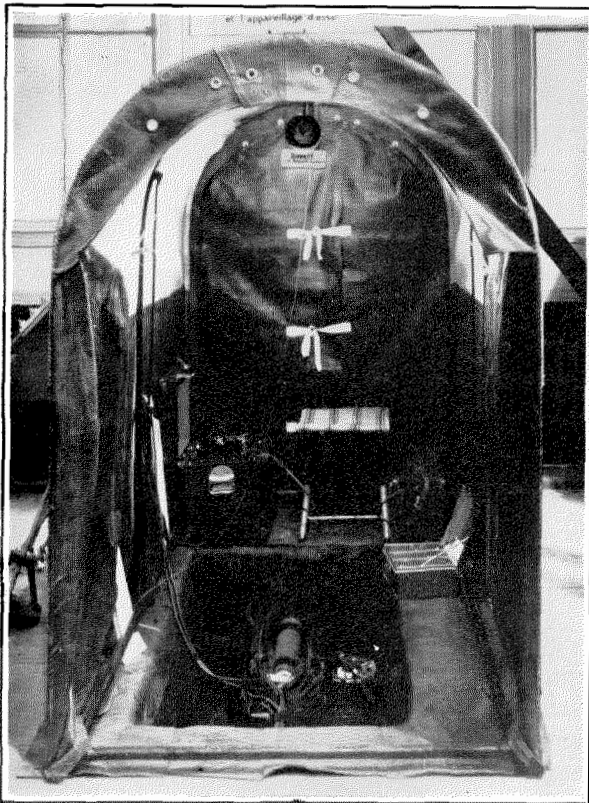

Figure 9—Jointers Tent showing jointing chamber with cable being jointed

Beneath the pole line were three examples of the methods of jointing loading pots into an underground cable. Two of these methods necessitated the erection of concrete protection chambers, Figures 4 and 5, but the third method, Figure 6, was somewhat easier to construct. The method represented in Figure 4

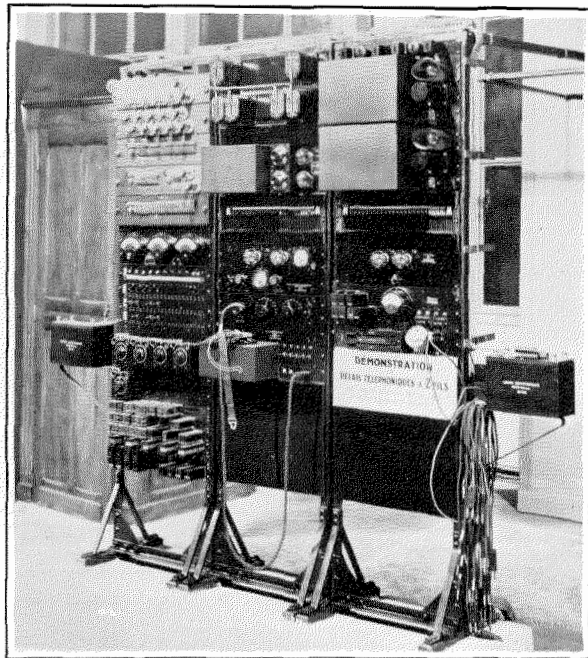

Figure 11—Two-wire Repeater Demonstration

is now being employed in various long distance cables, which the International Standard Electric Corporation is installing in Czechoslovakia, Austria and Hungary. The cable to which the loading coil stubs are jointed in this series of illustrations is a section of the Paris-Strasbourg cable. In this method, a manhole is made sufficiently large to hold several loading pots, ultimately destined for the joint at that point. This system gives maximum flexibility and accessibility.

The method shown in Figure 5 is used throughout the Stockholm-Göteborg cable sys-



tem. The base of the pot is buried and rests on a suitable foundation of concrete or of railway sleepers, while the stub cables and joint are protected by a concrete structure mounted on the top of the pots themselves. The concrete protection box is so designed that on removal of the six inches or so of earth which would cover the top, the lid can be pulled off and the sides moved outwards until the joint is easily accessible.

Figure 6 illustrates a method recently developed for use in tropical countries where fre-

was sealed off and a pressure cap was fitted. Near this end of the cable was a small exhibit of pressure testing equipment (Figure 8) arranged so that the methods employed in this system could be demonstrated. This exhibit was provided by Société Anonyme, Lignes Télégraphiques et Téléphoniques, Paris, an Allied Company of the International Standard Electric Corporation.

A pit was utilized to exhibit a jointers' and testers' equipment in operation at a cable splice, as shown in Figure 9. The cable—another

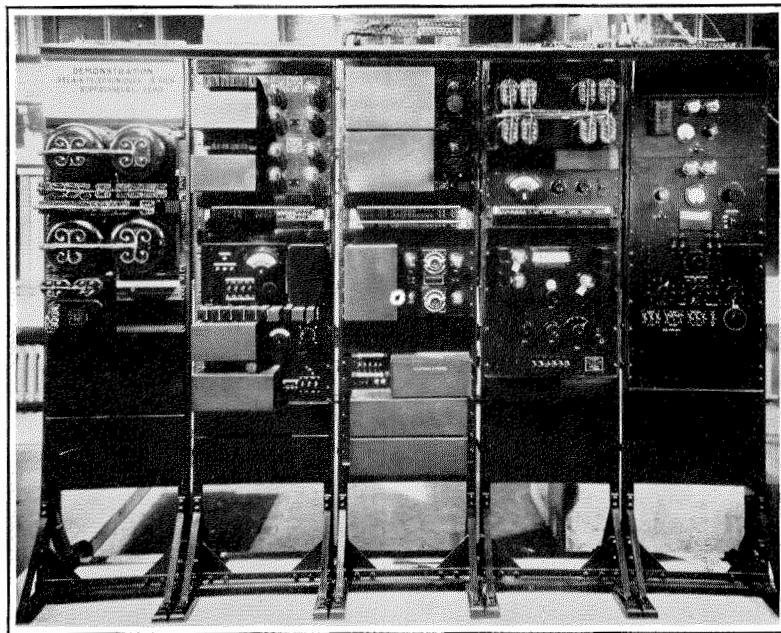

Figure 12—Four-wire Repeater, Echo Suppressor and Composite Telegraph Demonstration

quently trouble develops not only from acid soils but also from the white ant which bores through exposed lead cable and attacks paper insulation. The loading coil stubs are protected by flexible metallic tubing sealed off at one end to the loading pot and at the other end to the steel protection box covering the joint, so that white ants cannot get at the lead itself. The whole structure represented in Figure 6 is intended to be buried in the earth on a suitable foundation.

The cable jointed into this series of loading pots was led off at one end through a joint to a series of protection boxes—seen in the foreground of Figure 7—and at the other end it

section of the Paris-Strasbourg cable—was led through a jointing chamber, where it was fanned out in the course of being spliced. A jointers' tent covered the splice, and all equipment normally to be found in such a situation was present—including jointers' kit and testers' instruments.

Near the tent was a block wiring exhibit. A brick wall was constructed, and fixed to this were various types of distribution boxes suitable for block wiring. An underground local cable was led up to these boxes, and distributed from them in weatherproof wire. This wall was used also to show a drop-wire from one of the aerial-line poles. A complete jointers' tool

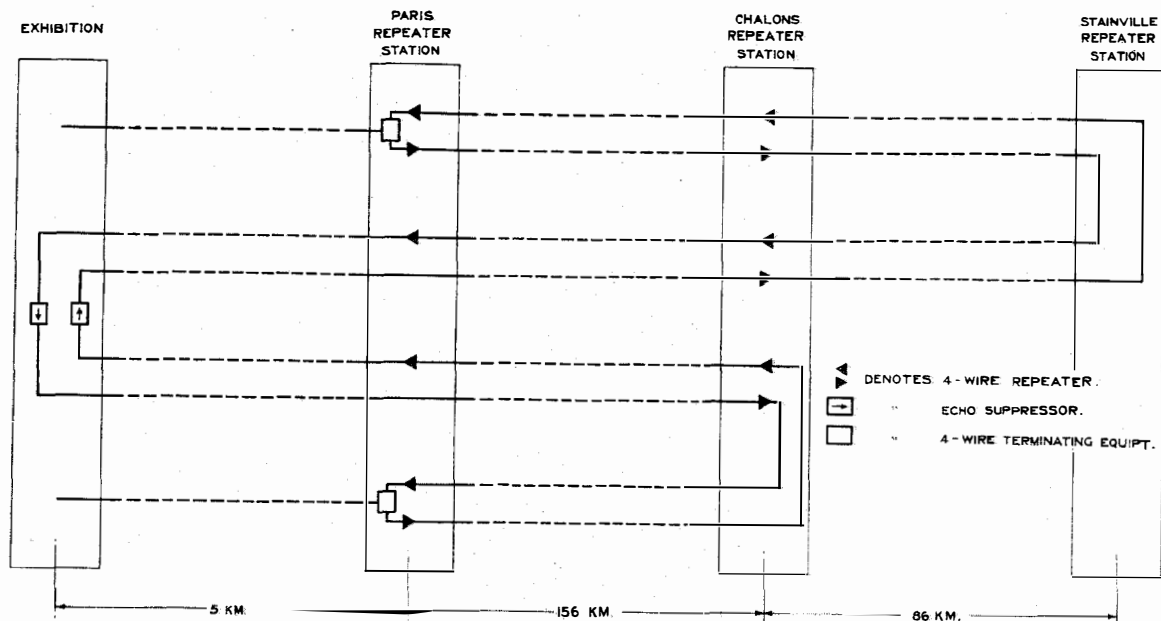

Figure 13—Echo Suppressor Schematic

kit was also shown mounted on a board adjacent to the block wiring exhibit.

Lastly, among the line plant exhibits was a varied collection of ducts, several installed with 2 and 3-way jointing boxes and concrete jointing chambers, and other appliances. Associated therewith were different types of duct rods. The ducts were mostly of the clay type, but concrete and fibre ducts, which specially interested telegraph delegates from countries in which clay is difficult to obtain, were also shown.

Two show cases were mounted with International Standard Electric Corporation cable sections, etc., and a third with a collection of sections of cables comprising the Stockholm-Göteborg system. A fourth exhibit in this category, Figure 10, consisted of three sections of local cable, fanned out to show the enormous number of pairs of small gauge which can be housed in a lead sheath of reasonable size. This exhibit was intended to draw the attention of delegates to the economy and trustworthy service to be derived from this type of local construction, as compared with aerial distribution, in densely populated areas. The largest cable in the illustration contains 1,200 pairs of 0.5 mm. conductors.

Another series of exhibits was devoted to

modern repeater equipment. It is now generally appreciated in Europe that there is a real necessity in international traffic for long, lightly loaded and repeatered cables, or under certain circumstances for nonloaded, repeatered aerial lines; there remain, however, very large areas in which this type of installation is not yet to be found. It was, therefore, of special

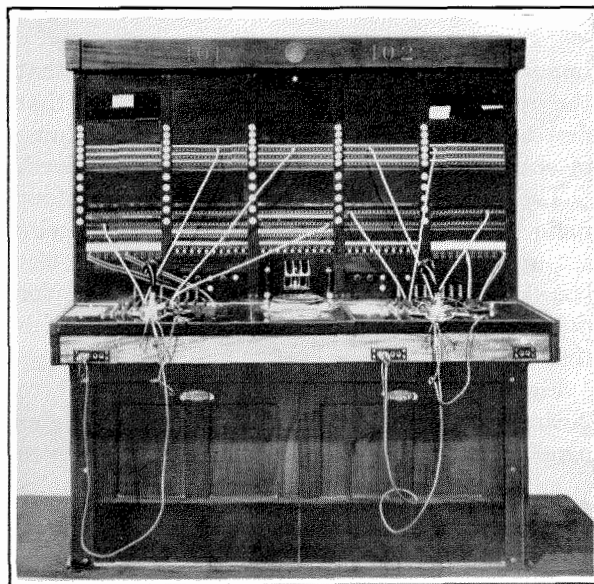

Figure 14—Two Position Toll Board

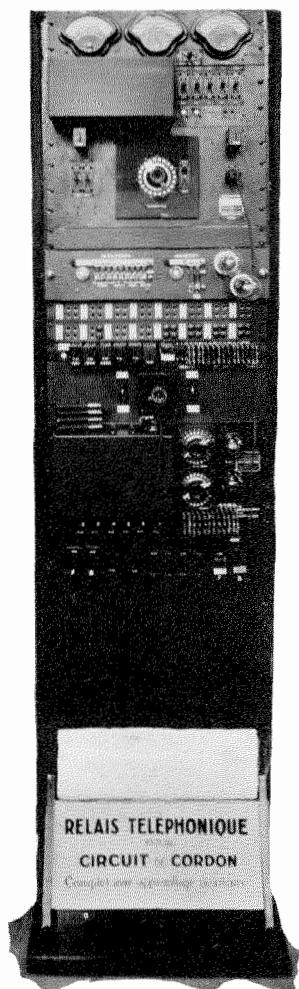

Figure 15—Cord Circuit Repeater

importance to a great number of delegates that the repeater exhibits were operating, so that first-hand judgment of the quality and volume of speech over long circuits could be obtained.

The repeater exhibit was divided into four main installations—a 2-wire set up, a 4-wire set up, a cord circuit repeater and a toll test board. Four silence cabinets were used for demonstration purposes in connection with these exhibits.

Figure 11 shows the three bays devoted to 2-wire equipment. The fuse panels, meter panels, etc., are on the left, while in the centre is a 2-wire repeater, gain measuring set, telephone and trunk panels, etc. On the right are two ringing panels arranged for ringing with 500 cycles per second modulated with 20 cycles per second. Below these is the ringer test

panel and oscillator for use with the gain measuring set. This set-up was operated through an artificial cable circuit of 36 TU between two of the silence cabinets.

Figure 12 illustrates the five bays fitted with 4-wire equipment. The left hand bay contains metallic composite equipment. The next bay contains echo suppressors, with their test panel and telephone and trunk panel. Next are two ringer panels, the 4-wire repeater panel, and a telephone and trunk panel, while the two right hand bays are occupied by a transmission measuring set, and an associated oscillator.

Two talking circuits were arranged for dem-

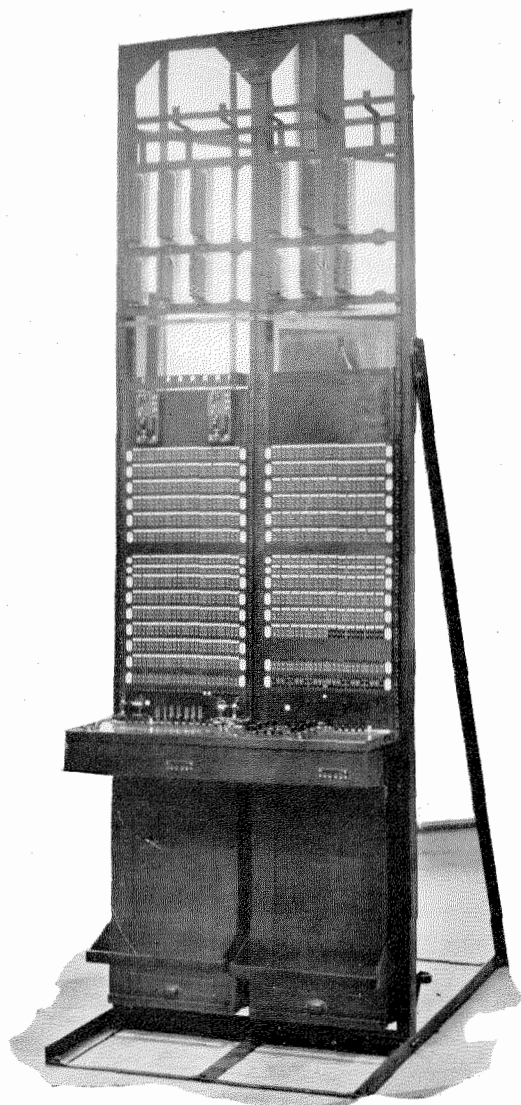

Figure 16—No. 5 Toll Test-board

onstration in connection with this exhibit. The first, incorporating the 4-wire repeater and voice frequency ringing, was connected up with artificial cables and the telegraphic metallic composite equipment between two silence cabinets. This was intended to show first of all the quality of reproduction of the 4-wire system and secondly the degree of quietness obtained on the talking circuit during the operation of

be borrowed from the Paris-Strasbourg cable system, so that a very effective echo was obtained without the suppressors in circuit, and delegates were able to appreciate the need for and effectiveness of these devices in long, medium-heavy loaded circuits.

A cord circuit repeater was demonstrated in connection with the 2-position toll board, Figure 14. The repeater itself is shown in



Figure 17—Repeater Station Test Desk

the metallic composite. For this purpose tables adjacent to the repeater bays were fitted up with the necessary telegraph equipment.

The second talking circuit employing 4-wire equipment was as shown in Figure 13, to demonstrate the echo suppressor. The French Telephone Administration was kind enough to arrange for six pairs to be available between the exhibition building and the Paris repeater station, Rue des Archives. Permission was given also for the medium-heavy loaded circuits to

Figure 15. This toll board was fitted with the switching devices necessary to enable the toll operator to bring the cord circuit repeater into circuit together with the correct balancing network, and means of controlling the gain of the repeater. Artificial cables of 5 TU for subscribers' loop, and 30 TU for toll connection, were used, as were also two silence cabinets.

The fourth exhibit relating to repeater equipment consisted of two bays of the No. 5 type toll test board shown in Figure 16. One of

these bays contained the voltmeter position and the other the Wheatstone Bridge position. This exhibit was not operated, but delegates had the

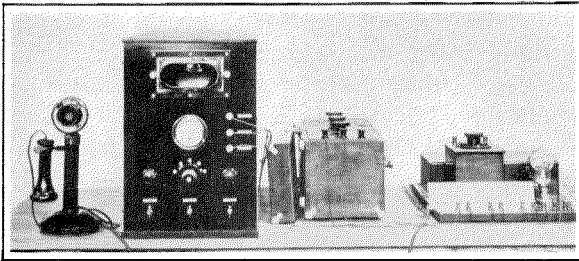

Figure 18—Oscilloscope Demonstration

bays, to other stations on the route, etc., and also means of picking up the necessary connections to the testing apparatus. For purposes of demonstration the aerial lines running up the room on poles were borrowed for testing trunks to the repeater bays, so that straightway measurements could be made from repeater bays to test desk, down the Paris-Strasbourg echo suppressors circuit, etc.

Other transmission testing instruments included a number of different types of oscillator. In order that their wave shape might be studied, the cathode ray oscillograph was employed, as illustrated in Figure 18. Use was

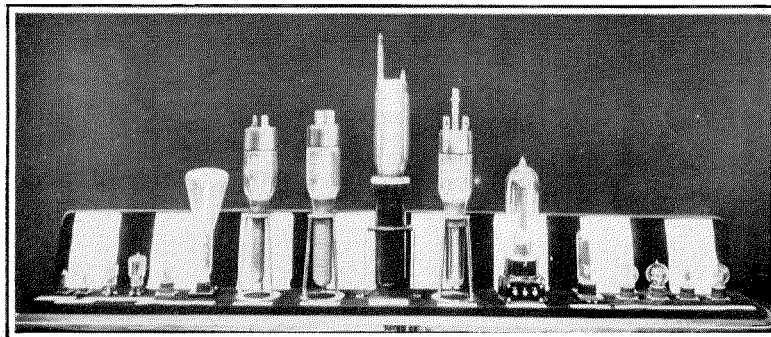

Figure 19—Vacuum Tube Exhibit

opportunity of appreciating the saving of cost and of space which this design effected.

A further important section of the exhibition related to transmission testing equipment. Part of this apparatus was, of course, to be found on the repeater bays. The demonstration of straightway tests and of transmission level measurements was rendered possible by the introduction of the transmission test desk, Figure 17, kindly lent by the British Post Office. It was designed and manufactured for the Derby repeater station, and was borrowed just before being installed. This type of desk, which is to be used throughout the toll route from London to Glasgow, is mounted with all the instruments ordinarily necessary for repeater station transmission tests—impedance measurements and measurements of transmission losses, gains and levels, and of repeater gains. A jack panel provides means of picking up testing trunks to the repeater bays, toll test board, etc., talking and ringing circuits to repeater

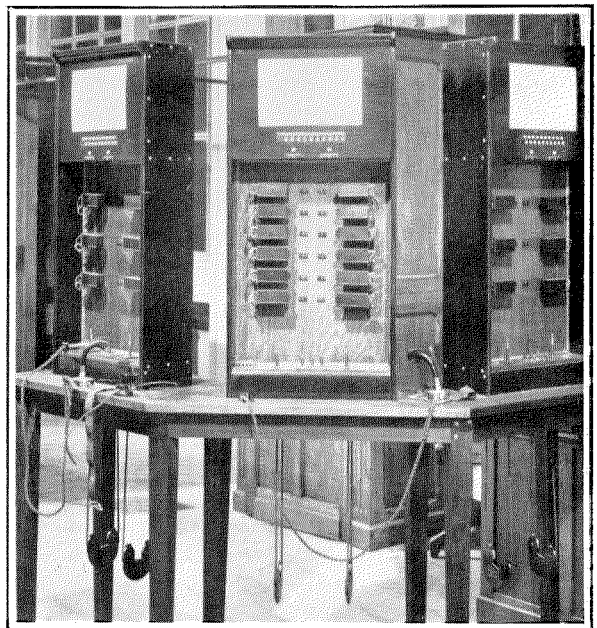

Figure 20—Exhibit of Universal, Semi-universal and Toll Cord Circuit Equipment

made of an easily tuned circuit to produce a horizontal time base; and very considerable interest was shown in the wave shapes, not only of the various oscillators, but also of the delegates' voices. To enable them to study their voices, a microphone was provided, and a switch for throwing either to "oscillator" or to "voice" wave shape.

In addition to the cathode ray oscillograph, Figure 19 shows a selection of vacuum tubes manufactured by the various companies associated with the International Standard Electric Corporation. Notable among this exhibit was a 10 KW Pyrex glass vacuum tube, of the type now in use at the Rugby<sup>2</sup> and Rocky Point Stations.

Microphones of different kinds, together with

<sup>2</sup> "Transatlantic Radio Telephony—Radio Station of the British Post Office at Rugby," E. M. Deloraine, *ELECTRICAL COMMUNICATION*, Vol. 5, No. 1, July, 1926.

cross-section cuts to show their construction, were also on view.

The model universal, semi-universal, and toll cord circuit equipment, Figure 20, was operated to show the latest practices advocated in toll switching.

The working exhibit included a telegraph keyboard perforator using only three rows of keys together with its associated automatic transmitter, these instruments being specially intended for use with Baudot multiplex equipments.

Photographs of typical installations and factories throughout Europe and tables of telephone statistics were hung upon the walls. On another floor of the building a cinematograph show was arranged in which a number of films revealed methods of apparatus construction, cable routes, etc., as well as the operation of various specimens of apparatus.



# A Modern High-Voltage Cable-Testing Plant

By T. N. RILEY

*Engineering Department, Standard Telephones and Cables, Limited*

## Introduction

IF there is any electrical development since the war in which progress has been more rapid than in long distance telephone communication, it is in long distance power transmission. National progress depends largely on cheap power, and it is becoming increasingly important that the economies, resulting from (1) station interlinking so that each operates at maximum efficiency, and (2) transmission of power from points where it can be generated cheaply to those where it is required for transport or industry, be fully realized.

The power engineer, unlike the telephone engineer, cannot be content with delivery of less than one-tenth or even one-hundredth of the power transmitted; on the contrary, he must lose less than one-tenth in transmission. Neither loaded lines nor repeaters are of assistance in the power field, and the only way of maintaining high efficiency as distances increase is to raise the pressure at which energy is transmitted.

In the United States, one system on the Pacific coast employs 220,000 volts 3-phase transmission, but such lines are extremely costly to construct and involve special problems of insulation and regulation. In Europe there are few places where power could not be generated locally from transported fuel at a cheaper rate than it could be transmitted from a distance great enough to justify the use of a pressure of 220,000 volts. Recent developments in the use of pulverized fuel have effected additional economies in steam station operation and have tended to turn the scale against a further increase in transmission distance. At present it is an open question whether future research will result in improved utilization of fuel with consequent limitation of the economical transmission distance or in the employment of higher pressures with longer transmission lines.

## Maximum Voltage and Test Requirements

When the requirements for the high-voltage cable-testing plant of Standard Telephones and Cables, Limited, were laid down, it was neces-

sary to decide the transmission voltage for which cable connections would be required within a reasonable period, bearing in mind the fact that cables intended for about 130,000 volt service were then only in the experimental stage. It was considered that while transmission voltages of 150,000 might be exceeded in certain districts, a demand for commercial cable connections to lines of higher pressure would not arise for many years. Inasmuch as the power delivered by a testing plant increases as the square of the voltage, and the cost rises nearly in proportion, it was obvious that provision for testing cable for operating pressures over 150,000 volts, 3-phase, would have involved an unjustifiable initial cost.

For a transmission line working at 150,000 volts it would be necessary to have three single-core cables each working at  $\frac{150,000}{\sqrt{3}} = 86,600$  volts to ground. A 3-core cable has certain advantages over a single-core cable, but considerations of handling make it necessary to limit the overall dimensions so that such cables cannot at present be economically built for pressures exceeding 66,000 volts, 3-phase.

The high-voltage testing plant, therefore, has been designed to make all necessary tests on:

1. Single-core cables up to 87,000 volts to ground.
2. 3-Core cables up to 66,000 volts between cores.

The electrical tests, any or all of which usually are called for on high-voltage cables, are:

1. Conductor Resistance.
2. Insulation Resistance.
3. Electrostatic Capacity.
4. Excess Pressure.
5. Load and Thermal Resistance of Dielectric.
6. Dielectric Loss.
7. Breakdown—On short samples only.

It is desirable to know the wave-form of the test voltage applied in tests 4, 6 and 7.



Of the tests enumerated, Nos. 1, 2 and 3, as well as a mechanical bending test usually specified only on short sample lengths, are carried out by long established routine methods applicable to low or high pressure cables, and call for no special comment. Only the plant required for special tests on high voltage cables will, therefore, be described. For these tests it

space was not available, an extension to the North Woolwich Works of Standard Telephones and Cables, Limited, was built to accommodate the new plant in which provision was made for all testing both of power and telephone cables. Figure 1 is a general view of the extension. In the foreground is a tank used for immersion tests on telephone cables. Behind this in an

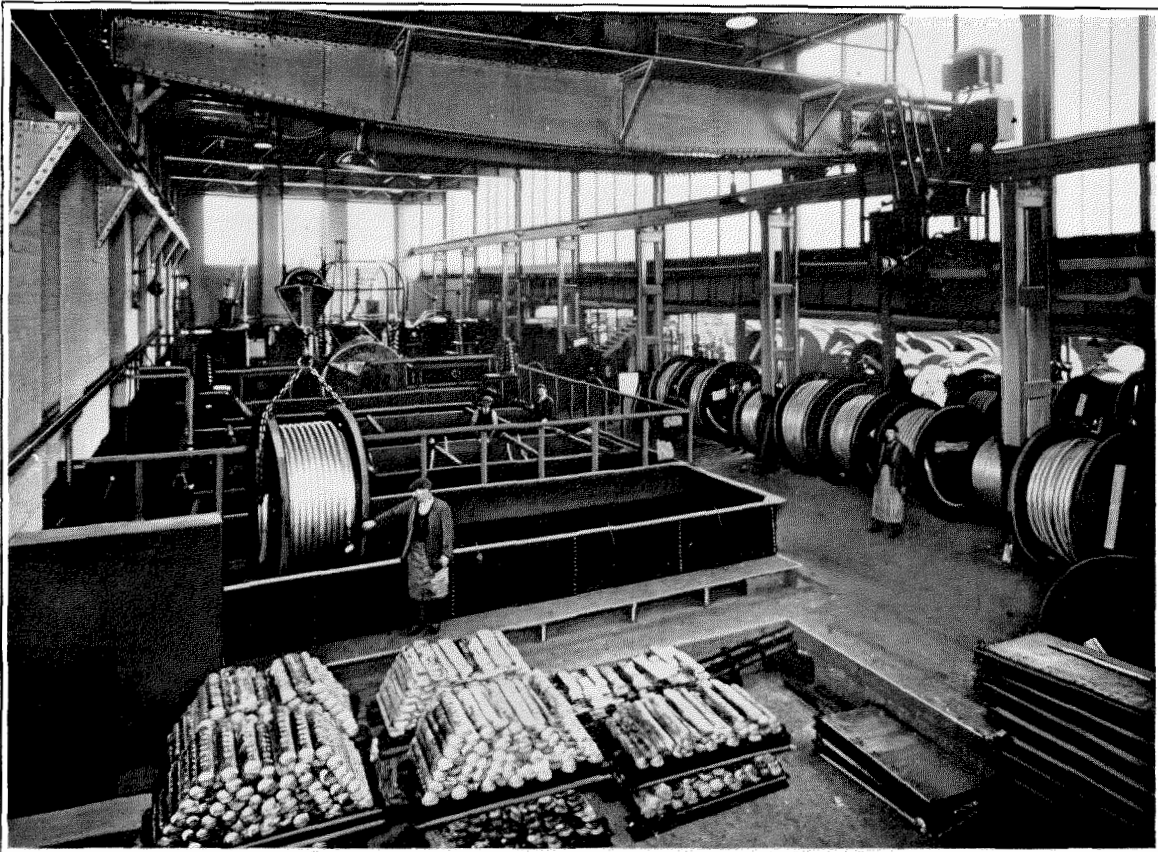

Figure 1—General View of Shop Extension

is necessary that pressures should be available considerably higher than the working pressures of any cables likely to be made now or in the near future. The reasons governing the choice of testing pressures for the plant will be given more fully hereinafter, but it may be stated here that the plant is capable of supplying 250,000 volts, 3-phase, or 450,000 volts, single-phase.

#### **Outline of Plant Arrangements**

For voltages of this magnitude, considerable clearances are required, and since sufficient

enclosure are three tanks for power-cable testing up to 60,000 volts. Cables in these tanks are tested from a 120 K.V.A. single-phase testing transformer on the opposite side of the gallery, to which connection is made by underground cable. The transformers as well as the testing tanks are located under the crane while the generators and control gear are placed under a gallery on the right.

Figure 2 shows the main control circuits for 3-phase pressure and load-testing, and also for measurement of dielectric losses and core temperatures. Some of the arrangements for extra

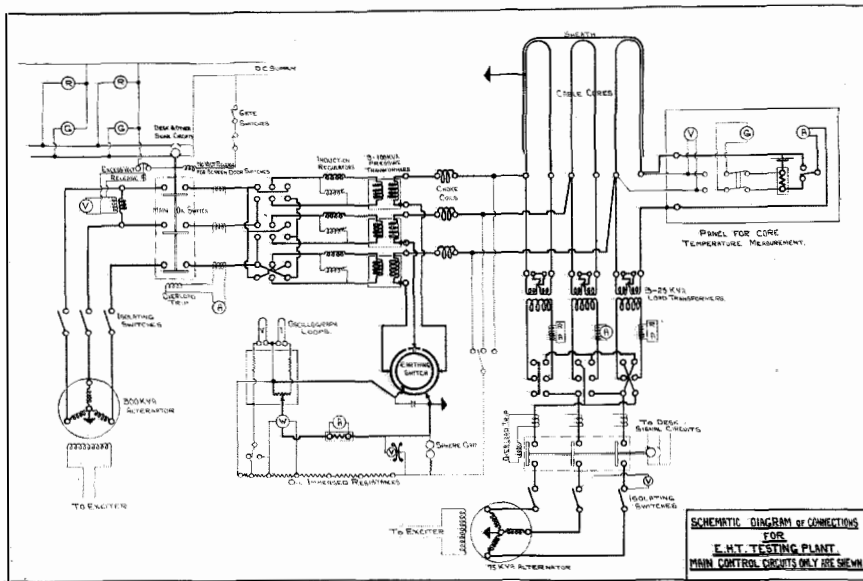

Figure 2—Diagram of Connections

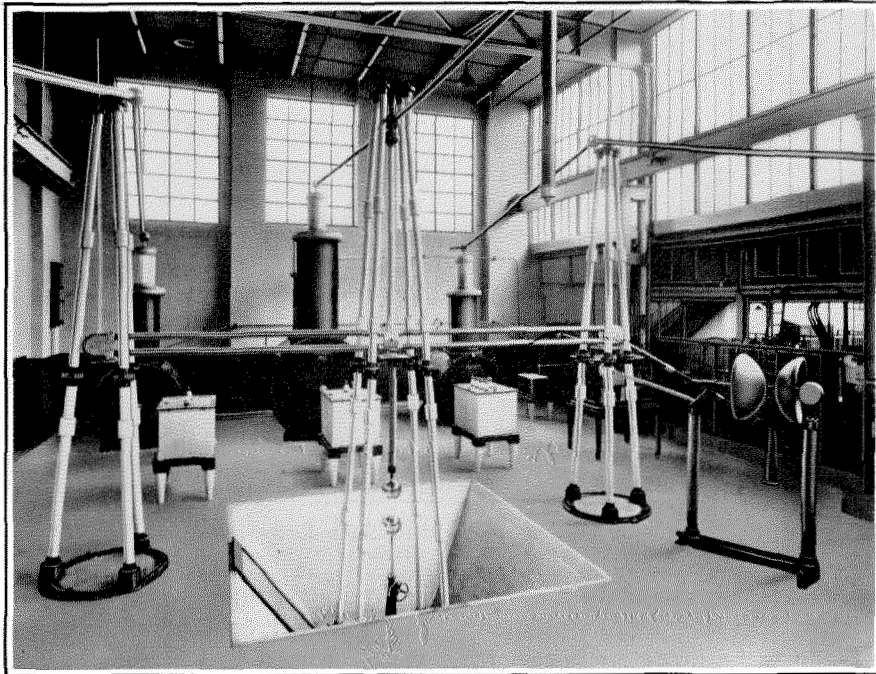

Figure 3—Pressure Transformers, Voltmeter and Spark Gap

high pressure single-phase testing and details of accessory circuits for motor supply, protective gear, etc., have been omitted for clearness.

### Pressure Test

High-voltage tests are applied from three 100 K.V.A. 150,000 volt transformers (Figure 3). These are oil-immersed self-cooled, and of a

special core type construction developed by Messrs. Ferranti for high voltage testing. The cores are mounted horizontally in the tank. This simplifies the problem of bringing out the end of the high-tension winding and reduces the overall height. The whole transformer is carried on rollers running on rails forming part of the tank. No crane is, therefore, required

to remove the transformer for inspection, but after running off the oil by simply unbolting the end plate and disconnecting the terminals, the transformer can be rolled out without disturbing the high-tension terminal.

Choke coils are incorporated in the high-tension terminal bushing to reduce the risk of voltage surges when a flashover or breakdown occurs on the cable under test. Pressure connections to cables under test are also made through liquid resistances for the same purpose.

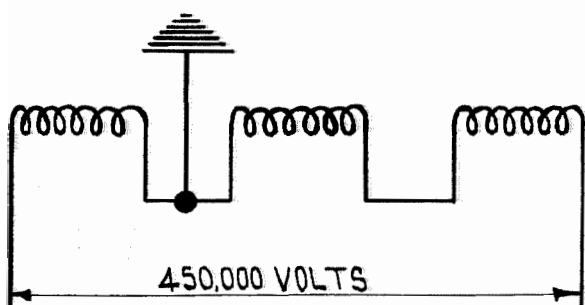

Figure 4—Connections for 450,000 Volt Single Phase Test

These resistances are enclosed in bakelite tubular containers, one of which is shown suspended from the center bus-bar in Figure 3.

For 3-phase tests, the high-tension windings are connected in star giving a maximum of 260,000 volts, 3-phase, or four times the working pressure of the largest 3-core cable which is likely to be built.

The high-tension winding of the center transformer is insulated for double its normal voltage to earth so that it may be connected in series with one of the other two transformers, giving 300,000 volts, single-phase. If, at the same time, the third transformer is connected as shown in Figure 4, a maximum pressure test of 450,000 volts A.C. may be applied to any sample on which both lead and conductors can be completely insulated. Switchgear is also provided so that two transformers may be coupled in parallel for additional single-phase output.

Connections to the cable under test are made through tubular bus-bars carried on porcelain pillars so that an overhead crane is free to move over the whole area.

The transformers are supplied through induction regulators from a 300 K.V.A. 3,000 V. alternator driven by a direct coupled motor

(Figure 5). This alternator is specially designed to give a close approximation to a sine wave even on a capacity load of low power factor.

### Pressure Control

The transformer voltage can be varied either by three single-phase induction regulators (Figure 6), or by variation of the alternator field which is supplied from a separate exciter. The three phases of the induction regulator can be independently hand operated, or can be coupled together and driven by a motor controlled from the main control desk. In order that excess voltage may not be applied inadvertently to any cable under test, arrangements are such that when the main switch is opened, the induction regulator automatically returns to zero boost; interlocks also are provided so that the main switch can be closed only when the alternator field rheostat is in the position for minimum voltage.

### Pressure Measurements

Measurements on the low-tension winding of the transformers are not trustworthy as an indication of the voltage on the high-tension winding, since the ratio of transformation changes with a variable load of high capacity. While a voltmeter is fitted on the control board to indicate the supply pressure, the test voltage is measured direct on the high-tension side by a four range Abraham-Villard type electrostatic Voltmeter which is shown on the right in Figure 3. This can be set for direct reading up to 300,000 volts, the scale being varied by adjusting the distance between the discs. The reading can also be checked by the flash-over distance between 10" spheres shown under the center bus-bar in Figure 3.

### Frequency Control

The driving motor of the alternator is arranged for an extra wide range of speed-control by field rheostat. It is thus possible to carry out a test at any frequency from 25 to 50 periods per second. The maximum test pressures referred to above are only available at 50 periods per second. At lower frequencies, the maximum pressure is reduced in direct proportion to the frequency.

### **Breakdown Test**

It has been the practice of some users to specify that a short sample of the cable shall be tested to breakdown. A test of this character is justifiable only when the determination of a factor of safety is practicable as, for example, in the case of homogeneous dielectrics such as porcelain insulators where breakdown is intended to occur by flash-over. For composite dielectrics of high capacity such as im-

pregnated paper cables, in which failure occurs by direct puncture, a breakdown test of this kind is of little or no value unless a factor of safety so high as to be impracticable under actual conditions of working is employed.

### **Load Tests**

There are several tests which require that provision be made for heating the cable by cir-

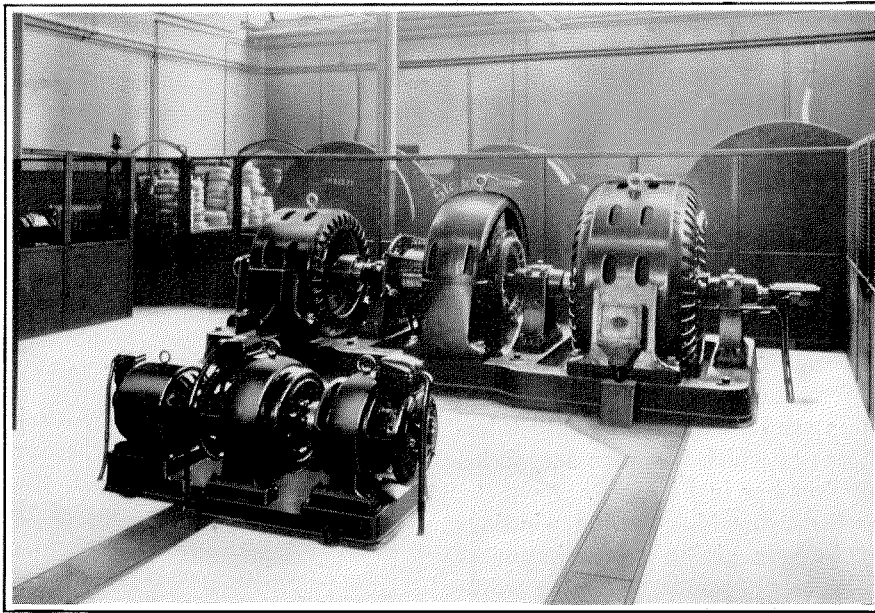

Figure 5—Motor Generator Set with Exciters in Foreground

pregnated paper cables, in which failure occurs by direct puncture, a breakdown test of this kind is of little or no value unless a factor of safety so high as to be impracticable under actual conditions of working is employed.

A modern well-made high-voltage cable will withstand six to eight times the working voltage for the usual factory test periods, but the time element enters largely into the voltage at which the sample will fail. The breakdown voltage on a sample, therefore, is no criterion of the safe working stress; and as its application in the case of the working voltages for which cable will be manufactured in the future would involve excessive plant capacity, it has not been considered necessary to meet such a test on more than 33,000 volt cables. The probabilities are that it will fall into disuse and that the

culating current through the cores. In the first place the difference in temperature between the copper and the lead, when steady conditions are reached, enables the thermal conductivity of the dielectric to be calculated. Secondly, it is necessary to have means for heating the core so that the effect of load, and consequently temperature variations such as occur in service, on the dielectric loss may be determined. Finally, some users require a temperature run on supervolt cables with a given load current circulating through the cores; in addition, after steady conditions are reached, a further run with pressure applied, the idea being that the difference of heating in the two cases will afford a measure of the dielectric loss at the temperature reached. The current carrying capacity for a given temperature rise is of course less

when the cable is tested on a drum in the factory than when it is laid in the ground, inasmuch as the effective radiating surface is considerably less when the cable is coiled on drum. The last test mentioned also requires that it should be possible to apply full voltage while circulating the load current.

For circulating current three 25 K.V.A. transformers are provided (Figure 7), giving either 400 amperes at 62.5 volts or 200 amperes at

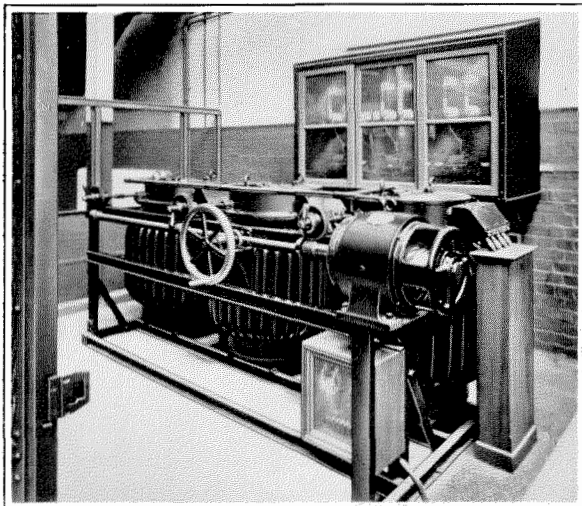

Figure 6—Induction Regulators

125 volts on the secondary winding which is insulated to withstand the full voltage to earth of the pressure transformers; viz., 150,000. Each core of the 3-core cable is short-circuited through one of these transformers while full pressure may be applied between cores, thus enabling the cable to be tested under actual full load conditions. Switchgear is provided for connecting these transformers in parallel, giving up to 1,200 amperes at 62.5 volts, or for connecting in series, giving 200 amperes at 375 volts, so that current may be circulated through a core of high impedance, as for example, a single-core cable on a drum.

The transformers are supplied from a 75 K.V.A. 400 volt alternator mounted on the same shaft as the alternator supplying the pressure transformers (Figure 5). The load current is varied by rheostat control of the alternator field.

In order to measure the rise of temperature of the cable core without interrupting a load

test, a special device is employed which has not hitherto been used on high-pressure circuits, although it has been employed on low-tension circuits in the research on buried cables carried out by the British Electrical and Allied Industries Research Association. By means of a well insulated switch, an 0.01 ohm shunt and a 2V. traction-type battery can be thrown into the circuit of one core. These are both capable of carrying the full load of 400 amperes alternating current, for short periods. A small direct current is thus superposed on the alternating current, and the relative potential drop across the cable core and across the shunt can be measured by a galvanometer which is sensitive to direct current voltage only. On the same panel are mounted an alternating-current ammeter to indicate the full load current and an alternating-current voltmeter to read the impedance drop in the core. The whole panel is insulated for 150,000 volts to earth, and is screened by a metallic screen connected to the supply bus-bar so that errors due to stray fields are avoided (Figure 8).

### *Dielectric Loss Testing*

With the development of the loaded telephone cable, the telephone engineer has been obliged to lay stress on the necessity for a low value of the alternating-current leakance. It is equally important that this should be low for power cables, though more to avoid dielectric heating than to improve transmission. It is still more important that it should vary very little with voltage over a range each side of the working voltage. A sudden increase of power factor with voltage indicates the presence in the cable of air spaces which are becoming ionized, and such a condition is likely to lead to early breakdown. Accurate measurement of the dielectric loss is, therefore, of high importance.

For this purpose it was decided to employ an electro-magnetic wattmeter since it is simple in theory, easily calibrated and commercially available. It can be used either for direct measurement of wattage loss, or, with a slight circuit modification, for measurement of loss angle by a null method.

A series of comparative dielectric loss tests subsequently carried out in the experimental

laboratory by various methods has shown that results which are in agreement can be obtained and that the electro-magnetic wattmeter will give accurate results on routine factory tests.

The Duddell-Mather Astatic Wattmeter installed is insulated to permit of its being inserted in the high-tension side of the circuit at pressures up to 75,000 volts, although it is nor-

tance on 3-phase measurements; for single-phase measurements these leakage currents can be avoided by connecting the wattmeter between lead sheath and earth.

The pressure coil of a wattmeter of this type can be connected to the high-tension circuit either through a potential transformer, or through a high resistance. For voltages of the

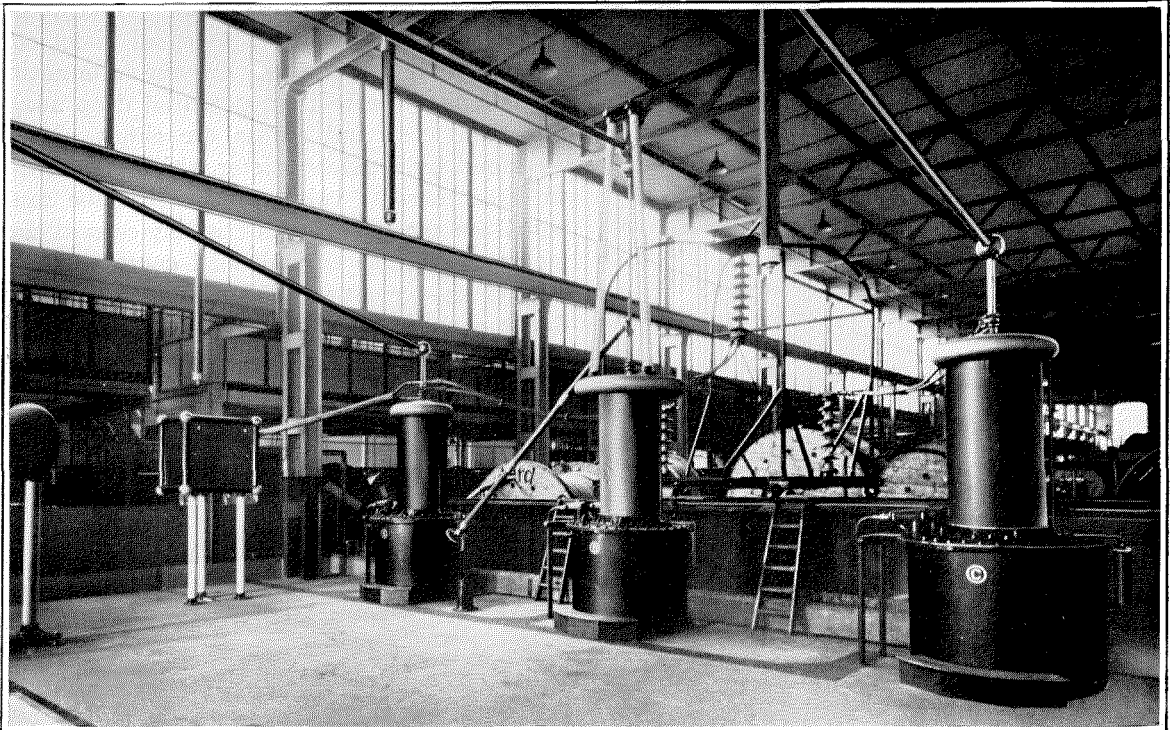

Figure 7—Load Transformers and Panel for Core Resistance Measurement. Testing tank in background

mally connected in the earthed side of the circuit. The wattmeter is seen in its screened case in Figure 9.

The current coil of this wattmeter is wound in sections which can be connected in series or parallel according to the charging current of the cable under test. By means of a special switch, this coil can be inserted in the earth connection of the high-tension winding of any of the pressure transformers without breaking the circuit. In order that the leakage currents from the high-tension winding itself may not flow through the wattmeter current coil, each transformer tank is lightly insulated and connected direct to the earthed side of the high-tension winding so as to act as a screen. This is only of impor-

magnitude involved, and for extremely low power factors, both methods involve risk of errors due to difference of phase between the applied voltage and the current in the pressure coil of the wattmeter.

If a potential transformer is used, the reactance of the windings causes the current in the pressure coil to lag behind the applied voltage, and since the cable-charging current leads by nearly  $90^\circ$  the effect is to give too low a loss reading and even in certain cases to give a negative reading. This can be corrected by suitable compensation circuits; but the required correction varies for each applied voltage since the reactance of the transformer varies with the voltage and a calibration must be carried



out with a pure capacity load—as for example, an air condenser.

If a high resistance is used, the error is due to the internal capacity of the resistance and to its capacity to ground. When the wattmeter is connected on the earthed side of the circuit, capacity between the series resistance and ground causes the loss readings to be too low,

distance connection to the pressure coil. This is in the form of an oil immersed, woven wire anti-capacity resistance divided into three sections of 250,000 ohms, each oil immersed in galvanized iron tanks. One of these sections is subdivided, and the wattmeter pressure coil of 100 ohms is connected in shunt to the last 1,000 ohms. This arrangement does not in-

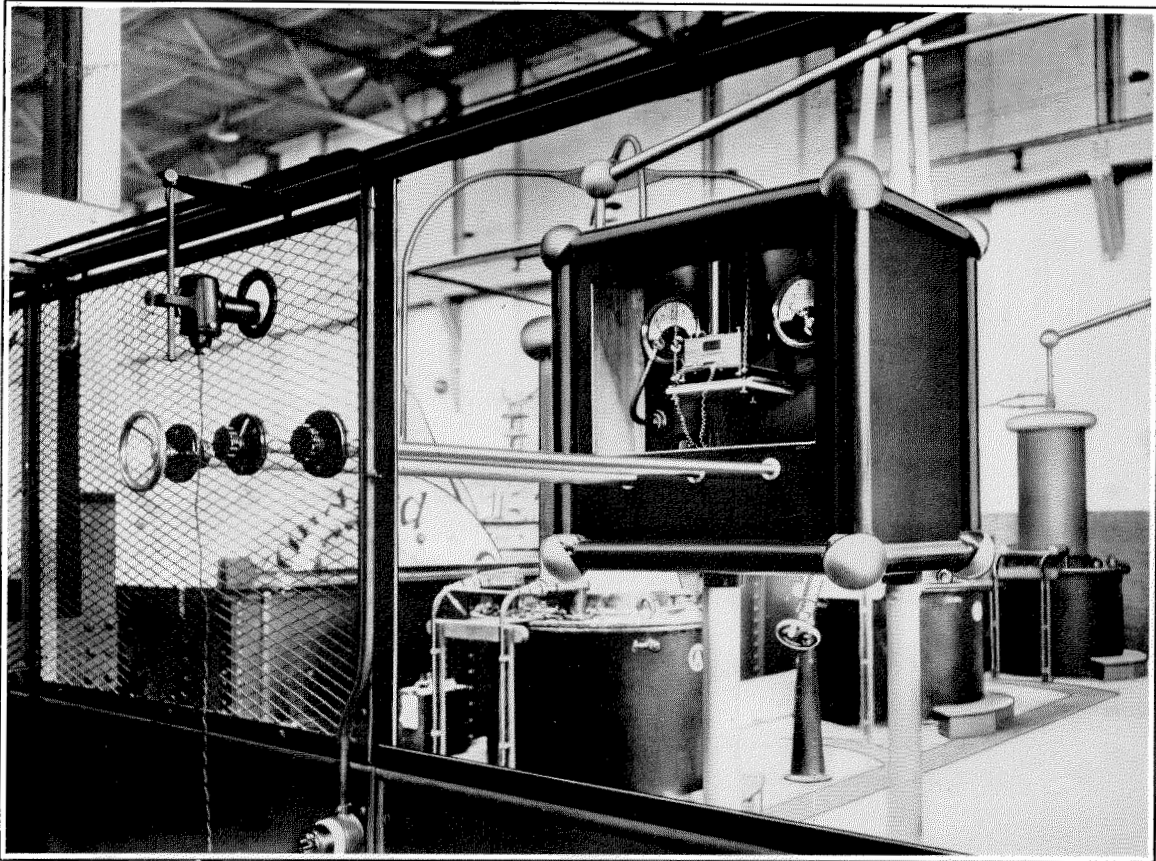

Figure 8—Panel for Core Resistance Measurement

while internal capacity causes them to be too high. These errors can be reduced by suitable arrangement of the apparatus, and by working so far as possible with the maximum current in the pressure coil, so that capacity effects are relatively small. As the two capacities also involve errors in opposite directions, they may cancel each other to a certain extent so reducing the total error to a negligible value. Even if they do not cancel, the necessary corrections are easily calculable.

For this reason it was decided to use a re-

volve any measureable phase-error, and ensures that an accidental opening of the pressure circuit on the instrument does not make it alive at the high potential of the pressure bus-bars.

For single-phase measurements, this arrangement is very satisfactory, but for 3-phase measurements the extra load in one phase due to the pressure-coil resistance causes an appreciable unbalancing of the voltage which considerably increases the difficulty of obtaining accurate loss readings. Since a potential transformer takes a much lower current than a high



resistance, experiments are now in hand with a view to determining whether the better voltage balance obtainable compensates for the increased difficulty in adjusting compensation circuits for accurate readings.

### *Wave Shape*

A Duddell oscillograph is provided for the determination of wave shape over the same

### *Testing Tanks*

The testing tank is divided into three sections which can be filled with water independently if a test is to be carried out with the cable immersed. The water in the center section can be heated by steam pipes if it is desired to make dielectric loss tests at various temperatures under uniform heating rather than by circulation of current in the cores. Connections are

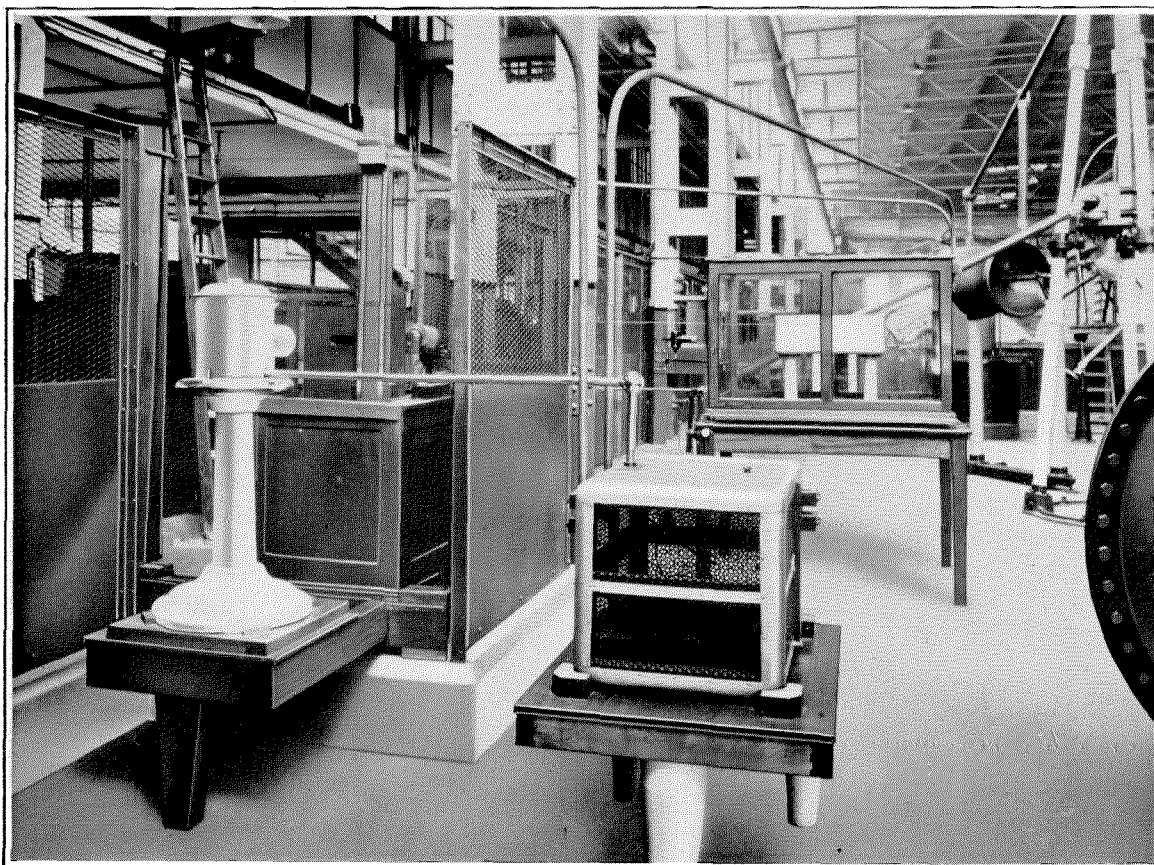

Figure 9—Wattmeter and Oscillograph

range of voltage as that for which losses are measured. This is shown in the foreground of Figure 9. The oscillograph itself is mounted on a porcelain pedestal so that it can be directly inserted in the high-tension circuit if desired. The auxiliary resistances are mounted in the screened cage on the right. Both these are inside the high tension area, and are separated from the camera by a sheet of plate glass tilted to avoid reflection.

made between the loading transformers and cables in any section through a special trolley insulator frame running on rails at the tank sides. This trolley is shown in Figure 7.

### *Control*

All parts of the plant which are raised to high potential are enclosed within an expanded steel partition which is solidly earthed. This partition is mounted on a one foot concrete

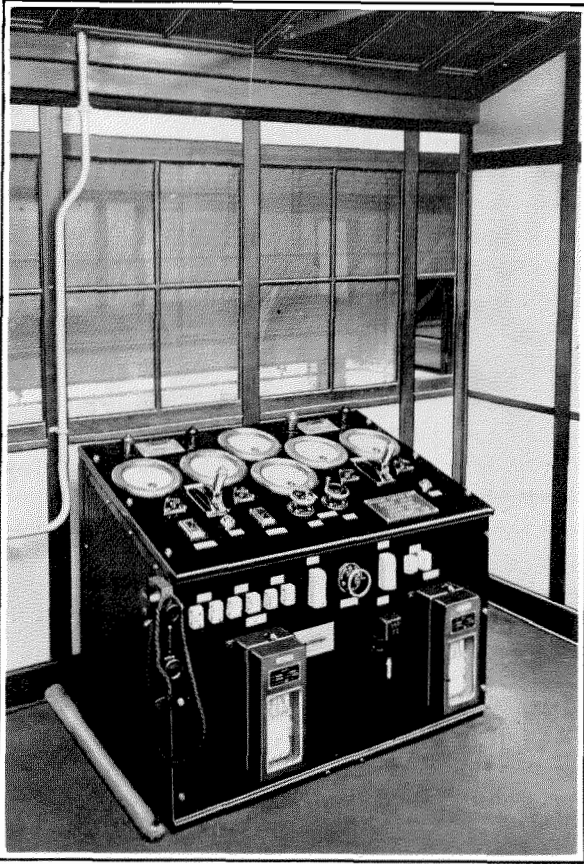

Figure 10—Control Desk

wall which is not broken even at doorways. The purpose of this is to confine the oil to the high-tension area in case of failure of a transformer tank. No operator is allowed to remain in the high-tension enclosure during a test. All switching operations can be carried on from outside this area, the gates of which are interlocked with the main switch supplying the pressure transformers, so that the main oil switch cannot be closed until the gates are closed, and the opening of the gates trips the main switch and cuts off the pressure. Red lamps are lit when the main switch is closed.

In order to move cables to and from the tanks, it is necessary that the overhead crane traverse the area. The danger signals normally warn the crane driver when a test is in progress, but as an additional safeguard, the closing of the main switch sets a trip on the crane supply circuit, so that should the crane accidentally travel past a certain point towards the high-tension area while a test is in progress, its power

supply is automatically cut off and it is brought to rest.

The main switchgear is centered in a control panel mounted in the gallery on the right of the high pressure testing equipment (Figure 3). This panel is shown in Figure 10. On the left hand side of the sloping face are the pressure transformer controls, including main switch, indicator lamps, ammeter and voltmeter for connection in any phase, and push button control for the induction regulator. In the center are volt and frequency meters for the alternator, field rheostat handwheels for both pressure and load supply, and, on the front face, a motor field rheostat for frequency control. On the right are the corresponding controls for the load transformer circuits. Mounted on the panel in front are two recording instruments so that continuous load records can be kept on a long period test.

### Results Obtained

Accurate testing facilities permitting comparison of various manufacturing processes are the first stage in cable development, but only the first. It is equally necessary that a similar standard of accuracy of control and flexibility be maintained in the manufacturing plant.

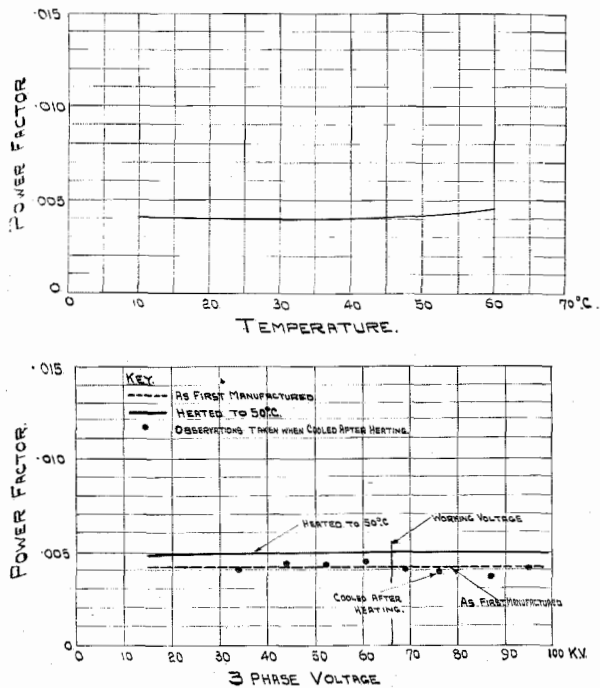

Figure 11—Test Results on 3-Core 66,000 Volt Cable

Space does not permit a description of the North Woolwich cable plant but it may be stated that the equipment for every manufacturing process is up-to-date and that some of the machines in use have been specially designed for these Works.

To illustrate the quality of the product being turned out by this factory, test results on a recent length of 66,000 volt, 3-core cable are given in Figure 11. To the power engineer, the curves will speak for themselves, but three points may be emphasized:

1. The power factor-voltage characteristic is practically flat, and there is no ionization as the voltage rises.
2. The power factor increases very little with temperature, so that the dielectric loss is still low even when the cable is carrying full load current.
3. The power factor-voltage characteristic is as good on cooling, after a test on load sufficient to raise the core to the working temperature, as it was initially.

This last point is of particular importance and is too often neglected in cable specifications. That a cable when first made will satisfactorily pass factory tests covering 1 and 2 above, is no guarantee that it will give permanent satisfaction in service. In order to secure this, it is necessary that there be no deterioration in these initially good characteristics after the cable has been subjected to the conditions which it will experience in service; i.e., fluctuations of temperature arising from changes of load. A repetition of the power factor-voltage test after a heat run shows whether this condition is fulfilled in so far as it can be checked by a short period factory test. If the power factor at the working voltage does not remain constant but is higher when the cable is cooled after a load test than it was originally, then there is risk that the power factor may become progressively worse with repeated changes of load, until the internal deterioration of the cable, of which the rising power factor is a sign, leads ultimately to breakdown.

---

#### CORRECTION

Article on "Recollections of Charles E. Scribner," by J. E. Kingsbury, January, 1927, issue.

On page 207, the reference to the author should have been given as "Late of Western Electric Company, Limited, London."

---

---

# *International Standard Electric Corporation*

Formerly

*International Western Electric Company*

INCORPORATED

*Head Offices*

NEW YORK, U. S. A.

*European General Offices*

LONDON, ENGLAND

PARIS, FRANCE

## *Associated and Allied Companies*

Standard Telephones and Cables, Limited.....*Aldwych, London, England*  
Branches: Birmingham, Glasgow, Leeds, Manchester, Dublin,  
Cairo, Johannesburg, Calcutta, Singapore.

Standard Telephones and Cables (Australasia), Ltd.....*Sydney, Australia*  
Branches: Melbourne, Wellington.

Bell Telephone Manufacturing Company.....*Antwerp, Belgium*  
Branches: Berne, The Hague, Brussels.

Standard Electrica, S. A.....*Madrid, Spain*  
Branch: Barcelona.

Standard Elettrica Italiana.....*Milan, Italy*  
Branch: Rome.

Standard Electric Aktieselskap.....*Oslo, Norway*

Le Materiel Telephonique.....*Paris, France*

Vereinigte Telephon und Telegraphen Fabriks.....*Vienna, Austria*  
Branches: Riga, Tallinn (Reval).

Standard Electric Company W. Polsce.....*Warsaw, Poland*

United Incandescent Lamps and Electrical Company, Limited.  
*Budapest (Ujpest), Hungary*

Compania Standard Electric Argentina.....*Buenos Aires, Argentina*

International Standard Electric Corporation, Branch Office.  
*Rio de Janeiro, Brazil*

Nippon Electric Company, Limited.....*Tokyo, Japan*  
Branches: Osaka, Dalny, Seoul, Taihoku.

Sumitomo Electric Wire & Cable Works, Limited.....*Osaka, Japan*

China Electric Company, Limited.....*Peking, China*  
Branches: Shanghai, Tientsin.

Sales Offices and Agencies Throughout the World

To those interested in better communication the International Standard Electric Corporation and its Associated and Allied Companies offer the facilities of their consulting engineering departments to aid in the solution of problems in Telephony, Telegraphy and Radio.